



**Translation of original
Operating Instructions**

**Core recycling
machine
Core Recycler**

291.000

From equipment I.D. No. :

Status :

April 2013

291 99 01



EC DECLARATION OF CONFORMITY

We

**Wiedenmann GmbH
Am Bahnhof
89192 Rammingen**

declare under our sole responsibility that the product

Core recycling machine Core Recycler

to which this declaration refers, corresponds with the relevant basic safety and health requirements of the machinery directive 2006/42/EC.

Rammingen, the 03.06.2013	Horst Wiedenmann
(Place and date of issue)	Managing Partner
	(Name, function and signature of authorised person)

Rammingen, the 03.06.2013	Peter Rischar
(Place and date of issue)	Technical office manager Authorised representative for tech. documentation
	(Name, function and signature of authorised person)

NOTE: The declaration of conformity is no longer valid if changes are made to the machine that have not been agreed with the manufacturer.



Declaration of conformity

We

**Wiedenmann GmbH
Am Bahnhof
89192 Rammingen**

hereby declare that the product

Core recycling machine Core Recycler

referred to by this declaration complies with the requirements of Machinery Directive 2006/42/EC.

Rammingen, the 03.06.2013	Karl Wiedenmann
(Place and date of issue)	Sales Manager
	(Name, function and signature of authorised person)

Rammingen, the 03.06.2013	Harald Reuen
(Place and date of issue)	Operations Manager
	(Name, function and signature of authorised person)

**Wiedenmann GmbH
Am Bahnhof
D 89192 Rammingen
Tel. No. : +49 (0) 7345 / 953-0
Fax No. : +49 (0) 7345 / 953 233
E-mail : info@wiedenmann.de
Internet : <http://www.wiedenmann.de>**

Preface

READ THESE OPERATING INSTRUCTIONS CAREFULLY to familiarise yourself with the correct way to operate and service your machine, and to prevent personal injury or damage to the machine. These operating instructions and the adhesive safety signs on your machine can also be obtained in other languages (your dealer can order these for you).

THESE OPERATING INSTRUCTIONS ARE a permanent part of your machine and should be handed over to the new owner if the machine is sold.

MEASUREMENTS in these operating instructions are given in the metric system. Only use suitable parts and screws. Different wrenches are required for metric and inch screws.

THE DESIGNATIONS "RIGHT" AND "LEFT" refer to the forward driving direction of **the self-propelled machine**.

ENTER THE PRODUCT IDENTIFICATION NUMBERS in the appropriate "Technical data" sections. Please ensure that all details are correctly recorded. These numbers can be of invaluable assistance for tracing the machine should it be stolen. Your dealer also needs these numbers when you order spare parts. We recommend that you additionally file these identification numbers in a secure place away from the machine.

BEFORE DELIVERY OF THIS MACHINE, your dealer performed a pre-delivery inspection to ensure optimal performance.

THIS DEVICE IS DESIGNED EXCLUSIVELY for commercial use and for use in golf course maintenance on greens and teeing areas, for collecting and processing cores. Coarse organic components such as lawn thatch are separated from sand and collected in the waste material container ("SPECIFIED USE").

Usage for any other purpose beyond this is considered as contrary to the intended use. The manufacturer accepts no liability for damage or injury resulting from this improper use. These risks are borne solely by the user. Compliance with and strict adherence to the operating, maintenance and repair conditions as specified by the manufacturer also form essential elements of the intended usage.

FORESEEABLE INCORRECT USE/MISUSE. It is not permitted to use the self-propelled machine to transport persons or things. The machine is **NOT** suitable for use on paved surfaces, general grass areas such as sports fields, or parks and artificial grass areas.

THIS MACHINE MUST ONLY BE operated, maintained and repaired by persons familiar with all its particular characteristics and acquainted with the relevant safety regulations. The relevant accident prevention regulations, all other generally recognised safety-related, occupational medicine and road traffic regulations must be adhered to. Any modifications carried out to this machine without the express approval of the manufacturer excludes the manufacturer of all liability for any resulting damage.

TABLE OF CONTENTS

Page

1.0. Safety Measures.....	6-14
1.1. Adhesive Safety Signs.....	11-12
1.2. Safety Equipment.....	13
1.3. Safety instructions.....	14
3.0. Transport.....	15
3.1. General information.....	15
3.2. Transporting the Core Recycler.....	16+18
3.3. Towing the Core Recycler.....	19
6.0. Operating.....	20-25
6.1. General information.....	20
6.2. Control elements.....	21+22
6.3. Checking the correct adjustment of the cylinder broom.....	23
6.4. Safety latch for working under the raised container.....	23
6.5. Adjusting the drum screen.....	24+25
6.6. Drum screen inserts.....	26
6.7. Engine drive.....	26
7.0. Operation.....	27-37
7.1. General information.....	27
7.2. Hot surfaces.....	27
7.3. Working with the Core Recycler.....	28
7.4. Correct sequence for engaging.....	29
7.5. Driving characteristics.....	30
7.6. Switching the machine off safely.....	30
7.7. Emptying the dirt container.....	31-32
7.8. Malfunctions and troubleshooting.....	33-37
8.0. Maintenance.....	38-54
8.1. General information.....	38
8.2. Maintenance and inspection list.....	39
8.3. Safety latch for working under the raised container.....	40
8.4. Removing the cleaning flap.....	40
8.5. Cleaning the Core Recycler.....	41
8.6. Cleaning the drum screen.....	42
8.7. Adjusting the brushes for the drum screen.....	43
8.8. Adjusting the scraper for the drum screen brush.....	43
8.9. Adjusting or resetting the hand brake.....	44
8.10. Checking and charging the battery.....	45
8.11. Electrical system.....	45
8.12. Removing and fitting the battery.....	46
8.13. Lubrication - General information.....	46
8.14. Lubricating points.....	47
8.15. Changing the oil in the Honda engine.....	48
8.16. Replacing the hydraulic oil.....	48
8.17. Hydraulics system.....	49
8.18. Removing and fitting the cylinder broom.....	50+51
8.19. Wheels and tyres.....	52
8.20. Disassembly / Disposal.....	53
8.21. Unauthorized conversion and spare part manufacture.....	54
9.0. Equipment.....	55
9.1. Scope of Delivery.....	55
9.2. Accessories.....	55
10.0. Specification.....	56-59

1.0. Safety Measures

RECOGNISE WARNING SYMBOLS

This symbol draws your attention to the safety instructions attached to the machine or contained in these operating instructions. It means that there is a risk of injury.

Follow all recommended safety instructions as well as the accident prevention regulations.



FOLLOW THE SAFETY INSTRUCTIONS

Ensure that you carefully read all safety instructions contained in these operating instructions as well as all those attached to the machine. The warning signs must be kept in good condition, i.e. readable. Replace missing or damaged warning signs. Ensure that new equipment and spare parts are provided with the appropriate safety signs. Replacement warning signs are available from your dealer.

Familiarise yourself with the operation of the machine and its control devices before working with the machine. Never allow a person without the appropriate knowledge to operate the machine.

Keep your machine in good working order. Unauthorised modifications to the machine can impair the function, operational reliability and service life of the machine.

If you do not understand any part of these operating instructions and need assistance, please contact your dealer.



1.0. Safety Measures

OBSERVE THE ROAD TRAFFIC REGULATIONS

Always observe local road traffic regulations when using public roads.



100.11

WEAR PROTECTIVE CLOTHING

Wear close-fitting clothing and the appropriate safety equipment for the work at hand.

Prolonged exposure to loud noise can result in impairment or loss of hearing.

Wear a suitable hearing protective device such as earmuffs or earplugs.

A safe operation of the machine requires the full attention of the operator.

Do not wear radio or music headphones while operating the machine.



100.12

SAFETY AND PROTECTIVE DEVICES

Safety and protective devices must be kept in proper working order and be fitted to the relevant location.

Always disengage the drive sections and shut off the engine before removing any of the safety and protective devices.

Keep hands, feet and clothing away from moving parts.

1.0. Safety Measures

STAY CLEAR OF ROTATING DRIVE SHAFTS

Carelessness in the area of the rotating drive shafts can result in serious injury or even death.

Always ensure that all shaft protection devices are fitted i.a.w. regulations and that the universal-joint shaft sheath tubing can turn freely. Wear close-fitting clothing. Shut off the engine and wait until all moving parts are at a standstill before adjusting or cleaning as well as connecting or disconnecting the PTO-driven machines.



EXERCISE CAUTION IN THE CASE OF LINE LEAKAGE

Leaking high-pressure fluids can penetrate the skin and cause serious injury.

The system must therefore be depressurised before lines are disconnected. Ensure that all line connections are leak-proof before the pressure builds up again in the system.

It is difficult to see hydraulic oil leaking from a small opening. For this reason, use a piece of cardboard when searching for leaks. Protect the hands and body from high-pressure fluids.

If any fluid penetrates the skin, this must be immediately removed by a doctor who has experience with this kind of injury. Failure to seek medical attention can lead to serious infection.

Doctors unfamiliar with this type of injury should reference a knowledgeable medical source.



1.0. Safety Measures

USE SAFETY LIGHTS AND EQUIPMENT

Avoid collisions with other road users. Slow moving tractors with mounted or towed equipment, and self-propelled machines on public roads pose a specific danger. Frequently check for traffic coming behind you, especially when making turns. Ensure safe traffic conditions by using hand signals or indicators. Use headlights, hazard warning lights, indicators and other safety equipment i.a.w. the respective legal provisions. Keep safety equipment in good working order. Replace missing or damaged parts. A set of safety lights is available from your dealer.



AVOID HEAT DEVELOPMENT NEAR PRESSURISED FLUID LINES

A highly flammable mist can form due to heat development near pressurised fluid lines. This can result in severe burns. Do not cause heat development by welding, soldering or using a welding torch near pressurised fluid lines or other flammable materials. Pressurised lines can be accidentally cut through when heat goes beyond the immediate flame area.



1.0. Safety Measures

REMOVE PAINT BEFORE WELDING OR HEATING PARTS

Welding should only be carried out by persons with a relevant qualifying certificate i.a.w. EN287.

Avoid the formation of toxic fumes and dust.

Hazardous fumes can be generated when paint is heated due to welding, soldering, or using a welding torch.

All work is to be performed outdoors or in a well-ventilated area. Dispose of paints and solvents i.a.w. the appropriate regulations.

Remove paint before welding or heating parts:

- The dust generated due to the sandblasting or grinding of parts must not be inhaled. For this reason, wear suitable breathing protection.
- Where a solvent or paint stripper is used, it must be rinsed off using water and soap before carrying out any welding. Then wait at least 15 minutes before welding or heating for the fumes to disperse.

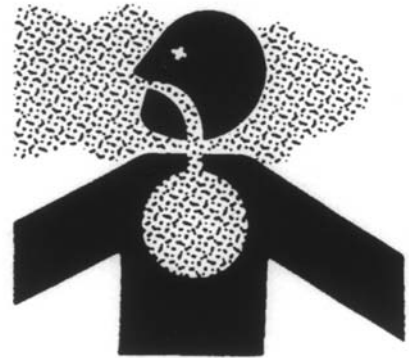

100.17

1.0. Safety Measures

1.1. Adhesive Safety Signs

Warning symbols

Warning symbols indicating danger are attached at some important areas on the machine. The hazard is identified via a warning triangle. A second symbol informs you how the injury can be prevented by acting appropriately. These warning signs, their placement on the machine and a brief explanation are given below.



Operating Instructions

These Operating Instructions contain all important information necessary for the safe operation of the machine. Carefully observe all safety instructions to avoid accidents.

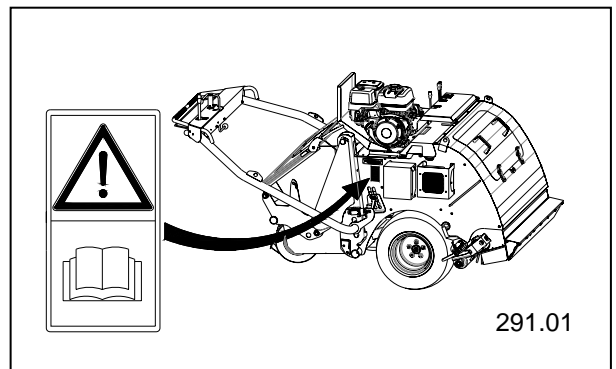

Swivelling range

Never reach into areas of crushing hazard as long as any parts may move.

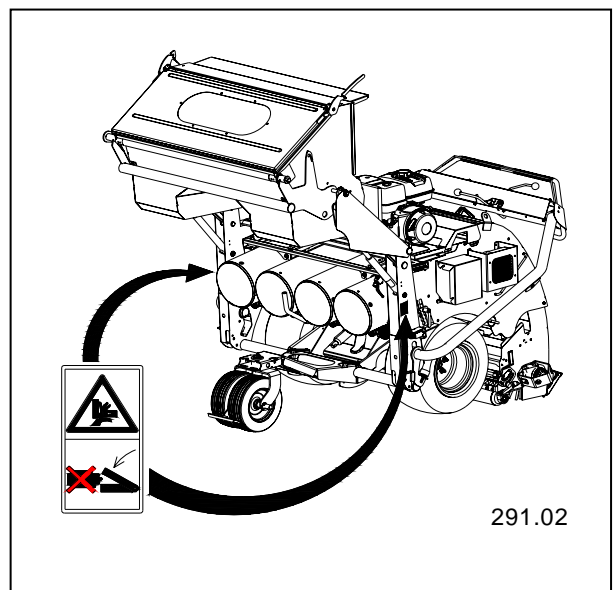

1.0. Safety Measures

1.1. Adhesive Safety Signs

Working below the raised container

Prior to working in the area of the raised hopper, the safety locking mechanism must be engaged.

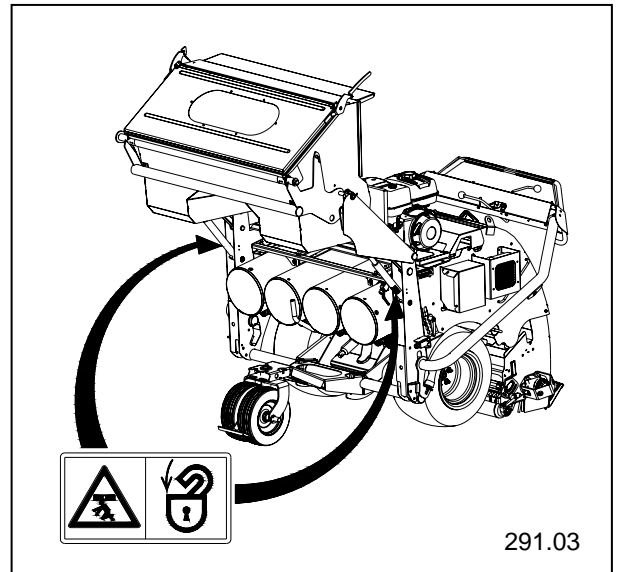

Battery

Prevent injuries! Battery fumes may explode:
Keep the battery away from sparks or naked flames.
Never place a piece of metal across the battery poles to check the battery charge.
Disconnect the earth terminal (-) of the battery first and reconnect it last.

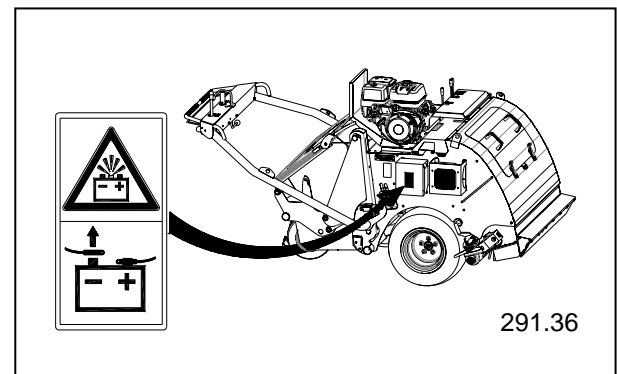

Maintenance

Shut off the engine and remove the key before performing maintenance or repair work.

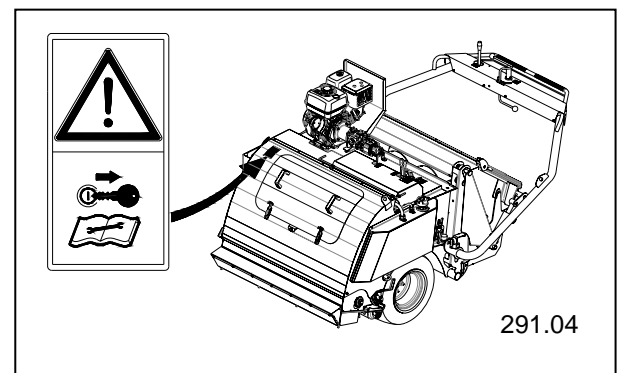

1.0. Safety Measures

1.2. Safety Equipment

GENERAL SAFETY SIGN REQUIREMENTS

A safety sign with the following safety practices or similar information shall be provided on the machine. The label should preferably be visible from the operator's position.

- a) Read the operating instructions.
- b) Do not operate the machine without safeguards, shields, and where the safety devices are not in place and working.
- c) Do not operate the machine when children and others are nearby.
- d) Do not allow untrained personnel to operate the machine.

ATTENTION DANGER !



Never use the CORE RECYCLER without safety equipment. Otherwise, you expose yourself and others to extreme danger.

⇒ Moving parts can result in serious injuries.

Where to find safety equipment on your machine

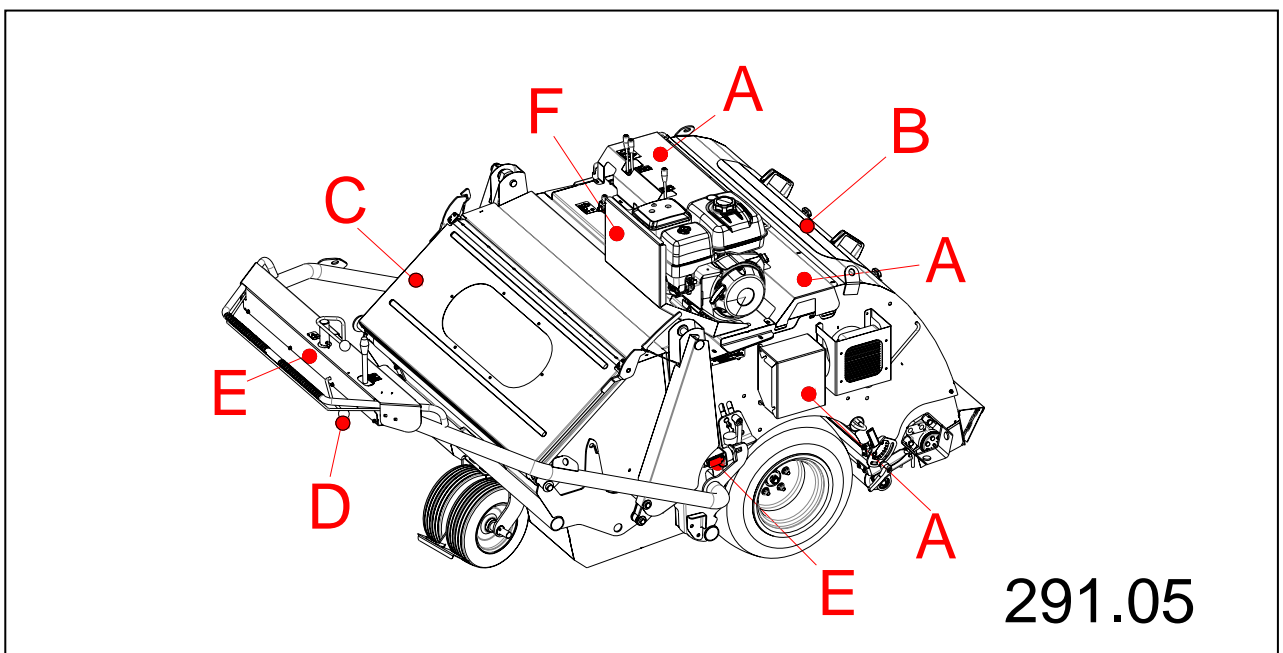

A = Protective covering for the hydraulics and the battery	D = Hand brake
B = Cleaning cover for the intake channel, can only be detached using a tool.	E = Contact switch and end switch which prevent unsecured starting and operation
C = Container cover can only be opened in the raised position	F = Protective equipment to protect the operator from noise and exhaust gases

1.0. Safety Measures

1.3. Safety instructions



- In addition to the information provided in these Operating Instructions, please also observe generally applicable safety and accident-prevention standards !
- Familiarise yourself with the function of all control elements and memorise how to switch off the engine quickly in an emergency. Ensure that the operator receives sufficient training before using the equipment.
- In the working area, the user is responsible for the safety of other persons !
- Before moving off, ensure that the immediate area of the machine is clear e.g. no children nearby. Ensure that your visibility is not impaired !
- Keep all persons clear of the danger zone of the machine !
- **Before starting any maintenance or repair work, the engine must be switched off. Remove the ignition key to prevent accidental start-up. In this way, possible risks can be eliminated:**
 - **Carbon monoxide poisoning due to engine exhaust gases**
 - **Burning due to contact with hot parts**
 - **Injuries due to contact with moving parts.**
- Use your personal protective equipment (PPE) for work, such as:
 - Work gloves;
 - Safety shoes;
 - Breathing protection;
 - Ear protectors;
 - Face and eye protection, etc.
- Special care should be taken when working and turning on a slope.
- DANGER OF TOPPLING !

3.0. Transport

3.1. General Information



CAUTION DANGER:

- The self-propelled machine is delivered secured on a transport frame.
- Only use fork lifts, cranes or hoisting gear with sufficient lifting capacity.
- Never stand under lifted loads. There is an imminent danger to life if the load falls.

Improper transportation of the **Core Recycler** may:

- injury to persons,
- damage to property.

Pay special CAUTION to the direction of approach when lifting the machine with the transport frame (see chapter 3.2.1.).

We do not accept any liability for damage resulting from improper handling.



CAUTION DANGER:

Caution must be exercised when cutting through the securing straps. Risk of injury due to ends "springing open".

3.0. Transport

3.2. Transporting the Core Recycler

3.2.1. Transport Using a Forklift

If the **Core Recycler** is still attached to the transport frame:

- Insert the forks under the transport frame (pay attention to the direction of approach),
- carefully lift the transport frame,
- unload the **Core Recycler** from the transport device when it is balanced,
- Remove top part and side parts of the transport frame,
- cut through the securing straps,
- lift the **Core Recycler** off the transport frame.

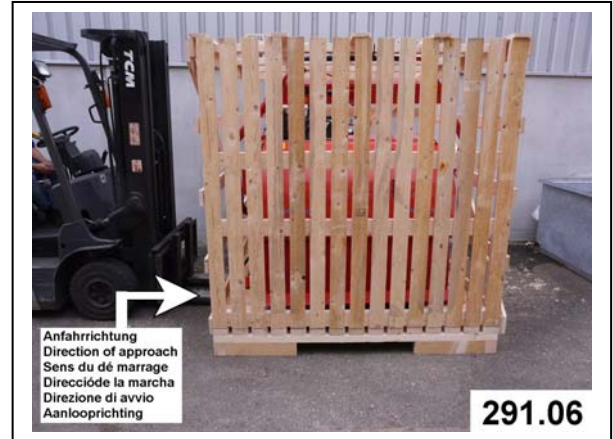

3.2.2. Transport Using a Crane

The following four points on the machine are provided to hitch it to a crane.

Point A: Two on the straps on the sweeping head

Point B: Two on the straps on the steering bar

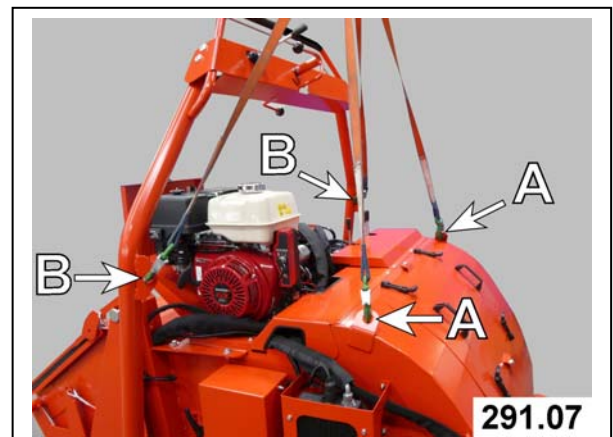

3.0. Transport

3.2. Transporting the Core Recycler

3.2.3. Driving the Core Recycler onto a trailer

A cover which can be driven on or three ramps with at least the same dimensions are suitable for driving on.

The length of the ramps must be at least four times the height to the loading area.

Ramps with non-slip surfaces.

Load-bearing capacity (one ramp)
min. 400 kg

Effective width more than 30 cm



CAUTION DANGER:

Only leave the machine on a sloping loading area with the hand brake applied. The machine may roll uncontrollably from the loading area and injure or kill people.

- RISK OF INJURY !

CAUTION DANGER:

Only leave the machine on a sloping loading area with the hand brake applied. The machine may roll uncontrollably from the loading area and injure or kill people.

- RISK OF INJURY !

Unlock the sweeping head limit (upwards) by pulling the handle **(A)**.

Raise the sweeping head

Drive forwards onto the loading area with an appropriately low speed.

Apply the hand brake.

Lower the sweeping head onto the loading area.

Switch off the engine and remove the ignition key.

Secure the Core Recycler (see chapter 3.2.4.)

Unloading is in the reverse order.



3.0. Transport

3.2. Transporting the Core Recycler

3.2.4. Mounting point for transport on a trailer

Tighten tie-down straps evenly, alternating diagonally across.

Side hooking points for belts



Hooking points for belts on the rear

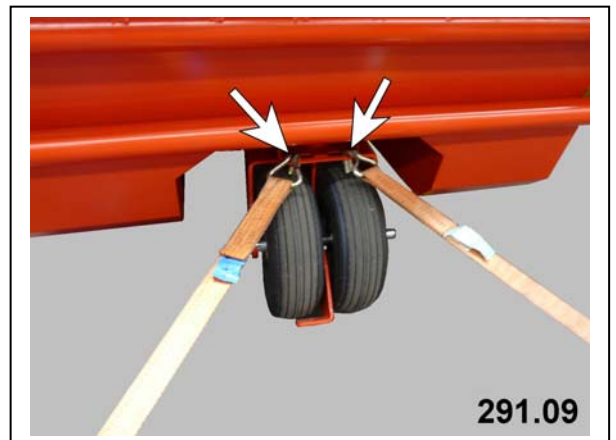

3.0. Transport

3.3. Towing the Core Recycler

To fasten a tow rope, a shackle (A) must be fitted on a lashing point above the steering wheels.

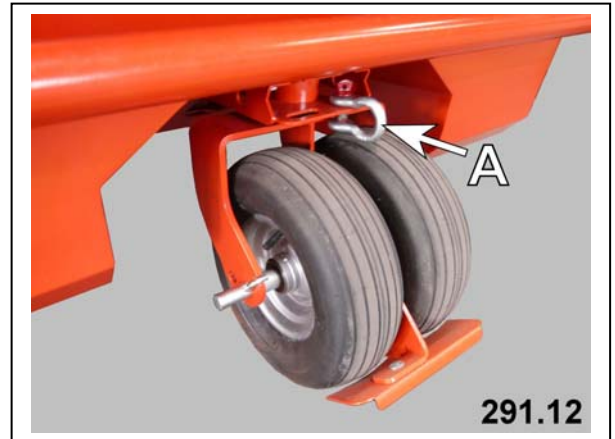

Pivot the steering bar to the sweeping head side.

The operator must accompany the machine during the towing process in order to be able to apply the hand brake in an emergency.

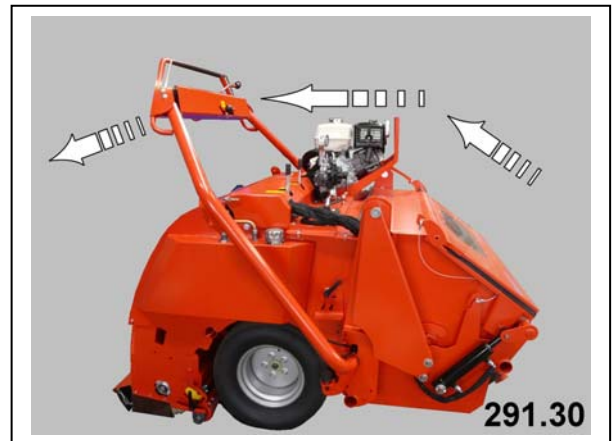

6.0. Before Initial Operation

6.1. General Information



CAUTION:

Before starting any work or adjustments (on the machine), the engine must be switched off. Remove the ignition key to prevent accidental start-up.

- RISK OF INJURY !







CAUTION!

The machine is **NOT** approved for travel on public roads.

Familiarise yourself with the function of all control elements and memorise how to switch off the engine quickly in an emergency. Ensure that the operator receives sufficient training before using the equipment.

6.0. Before Initial Operation

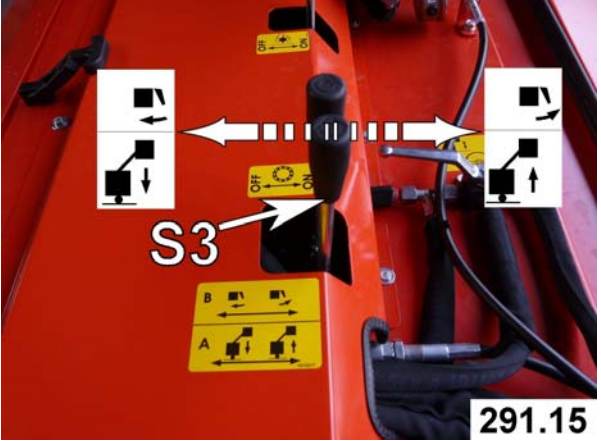
6.2. Control elements

<p>Control lever (S1) for the cylinder broom drive</p> <p>“ON” switch</p> <p>“OFF” switch</p>	 <p>291.13</p>
<p>Control lever (S2) for switching the drum screen on and off</p> <p>“ON” switch</p> <p>“OFF” switch</p>	 <p>291.14</p>
<p>Control lever (S3) for emptying the container in conjunction with the ball valve (S4)</p> <p>Function A: Raises and lowers the container</p> <p>Function B: Tilts the container to empty it and opens the cover Swings the container back and closes the cover.</p>	 <p>291.15</p>
<p>Ball valve (S4)</p> <p>In position “A”: Raises and lowers the container</p> <p>In position “B”: Tilts the container to empty it and opens the cover Swings the container back and closes the cover.</p>	 <p>291.16</p>

6.0. Before Initial Operation

6.2. Control elements

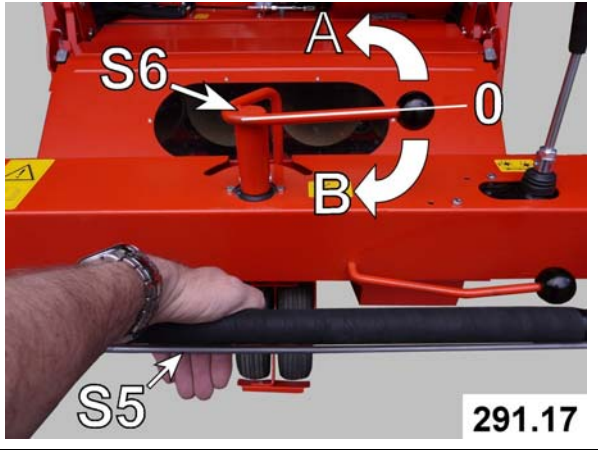
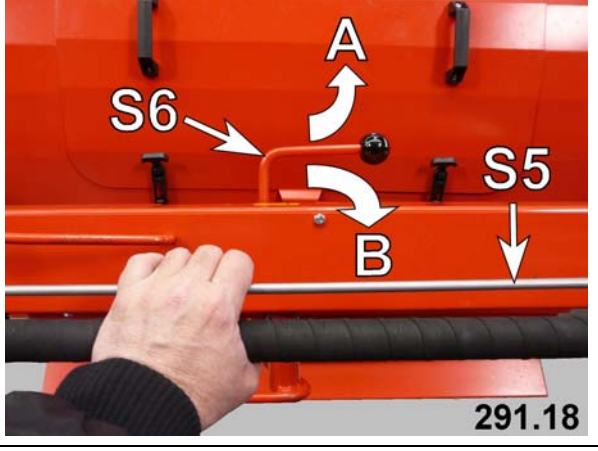
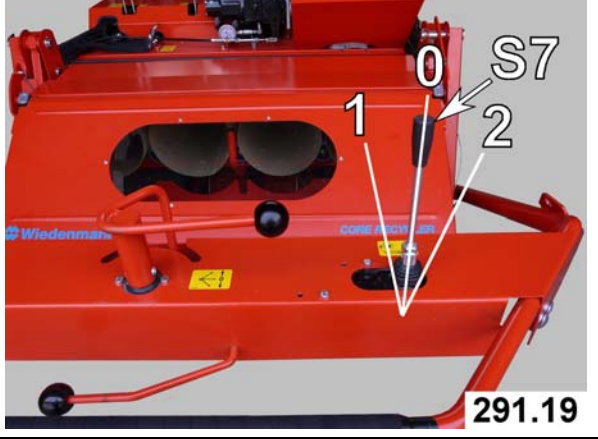
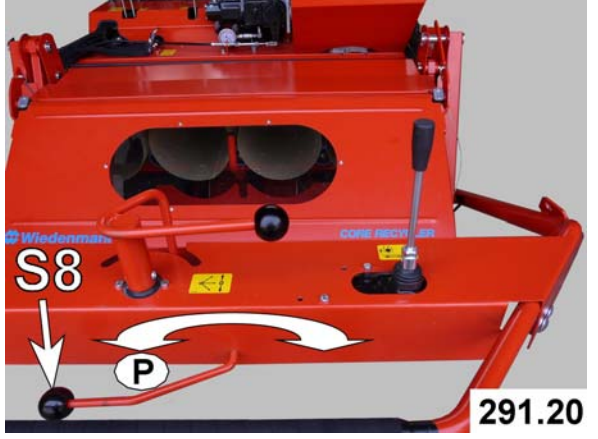
<p>Drive unit (steering bar in the working position)</p> <p>Control lever (S6) in direction “A” for forwards</p> <p>Control lever (S6) in direction “B” for backwards</p> <p>Safety catch (S5) must be pulled towards the handle by hand.</p>	 <p>291.17</p>
<p>Drive unit (steering bar pivoted to empty the container)</p> <p>Control lever (S6) in direction A for forwards</p> <p>Control lever (S6) in direction B for backwards</p> <p>The safety catch (S5) must be pushed towards the handle by hand.</p>	 <p>291.18</p>
<p>Raise or lower the sweeping head</p> <p>Push control lever (S7) to Pos. 0 Pos. 1 Raise the sweeping head Pos. 2 Floating position</p>	 <p>291.19</p>
<p>Hand brake (S8)</p> <p>To apply, pivot 180° to the left</p> <p>To release, pivot 180° to the right</p>	 <p>291.20</p>

6.0. Before Initial Operation

6.3. Checking and resetting the correct adjustment of the cylinder broom

The distance from the cylinder broom to the front wall should be 3 - 4 mm.

The distance (dimension **X**) from the ground to the cylinder broom should be at least **10 mm**.

Carry out the adjustment on a flat, paved surface.

Undo the clamping levers (**A**) on both sides.

Raise or lower the roller using the adjusting lever (**B**).

tighten clamping lever (**A**)

Check adjustment again after several metres.

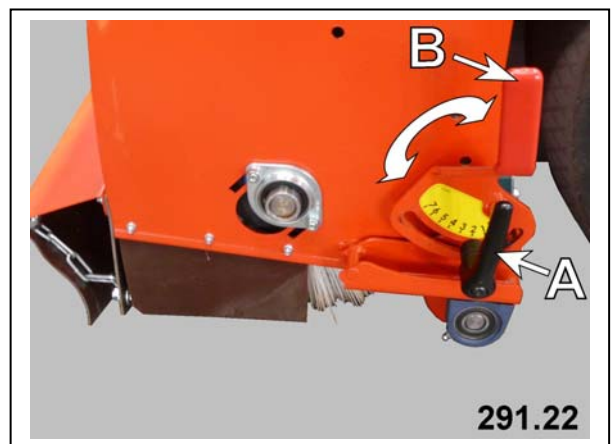
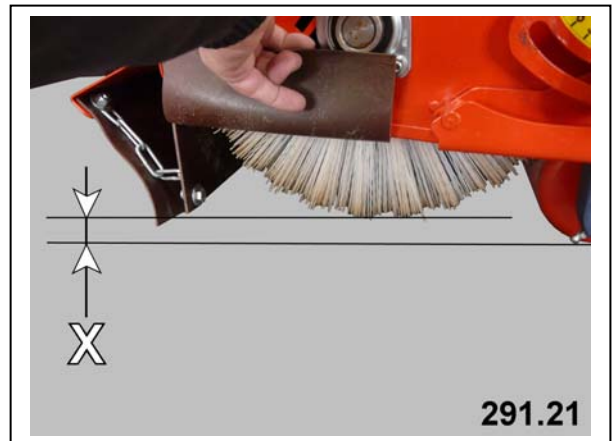

6.4. Safety latch for working under the raised container



CAUTION:

Before all work on the raised container, the safety latch must always be engaged to prevent the container from dropping unexpectedly.

- RISK OF INJURY !

- Raise container fully during high dumping.
- Pull the ball valve lever backwards and rotate it to the right by 90° (see Figure 398.29).
- Pull the ball valve lever backwards and rotate it backwards by 90° to release the container.

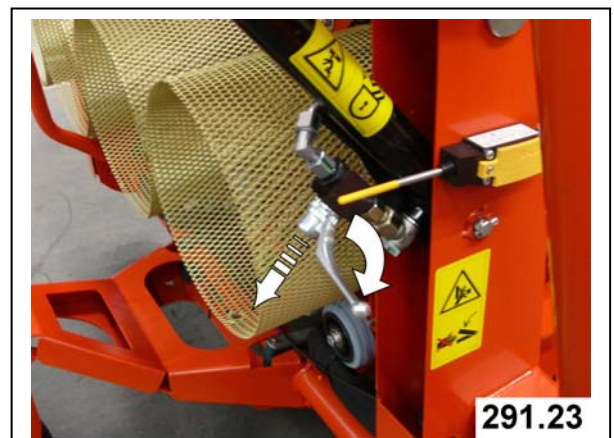

6.0. Before Initial Operation

6.5. Adjusting the drum screen

Position T1:	Position T2:
Default setting	<ul style="list-style-type: none"> • For very dry working conditions and small amounts of material • For low screening • For closed screens and sharply undulating terrain

1. Switch off the cylinder broom drive with control lever **S1**.
2. Switch off the drum screen drive with control lever **S2**
3. Pivot the steering bar to the other side.
4. Switch off the engine.
5. Apply the hand brake.



Changing from position T1 to position T2:

6. On one side, undo the toggle screw (**A**) until the retaining plate (**B**) can be changed to position 2 (see Fig. 291.24).
7. Tighten the toggle screw (**A**).
8. Now carry out the adjustment on the opposite side.
9. Only tighten the toggle screw (**A**) until the retaining plate (**B**) is still loose.
10. Pivot the steering bar to the other side (working position **P1**).
11. Undo the first toggle screw (**A**).
12. Push the retaining plate (**B**) down by hand until it is resting on the rubber-bonded metal buffers on the steering bar.
13. Tighten both toggle screws.

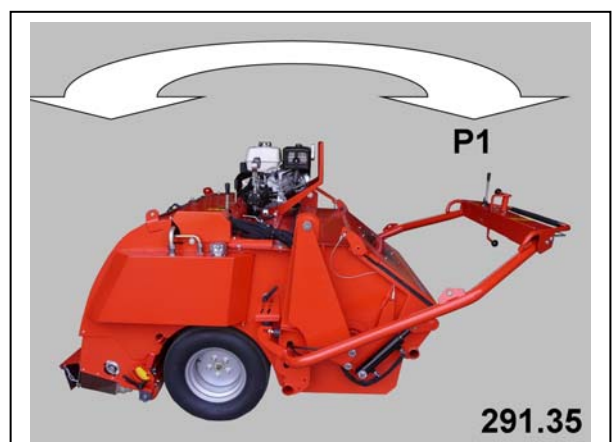
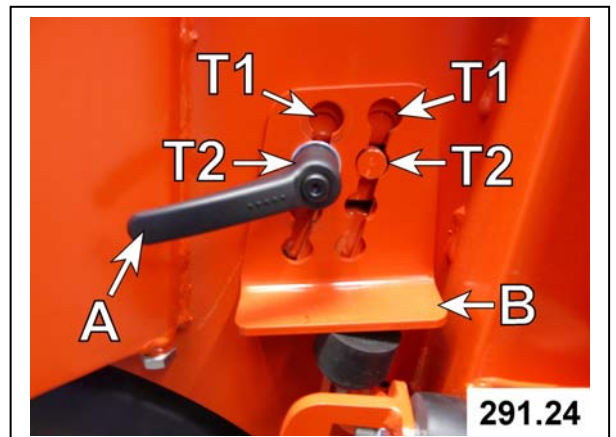

6.0. Before Initial Operation

6.5. Adjusting the drum screen

Changing from position T2 to position T1:

14. Undo the toggle screw (A) on both sides.
15. Change the retaining plate (B) to position T1.
16. At the same time, the drum screens can slide downwards.
17. Only tighten the toggle screw (A) until the retaining plate (B) is still loose.

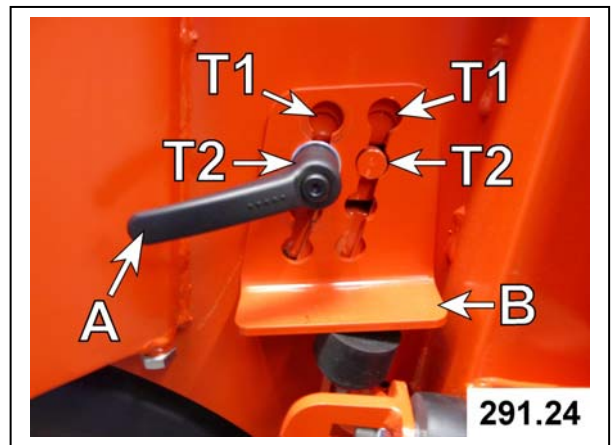

18. Pivot the steering bar into working position P1, and at the same time, raise the drum screens to the required position.
19. Tighten the toggle screws (A) on both sides.

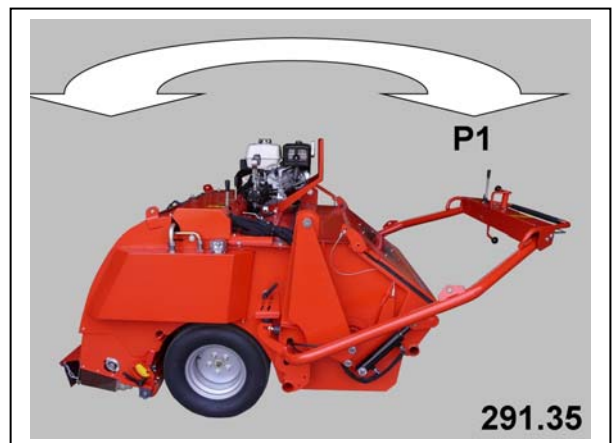

6.0. Before Initial Operation

6.6. Drum screen inserts

All of the collected material is conveyed directly and unsifted into the waste material container by the inserts.

CAUTION:

Observe the permissible total weight and the permissible axle loads.

Roll up the insert **(A)**; when doing this, the hexagon nut **(B)** should always be on the outside.

Push a rolled up insert **(A)** into each drum screen and click into place in the notch **(C)** with the nut **(B)**.

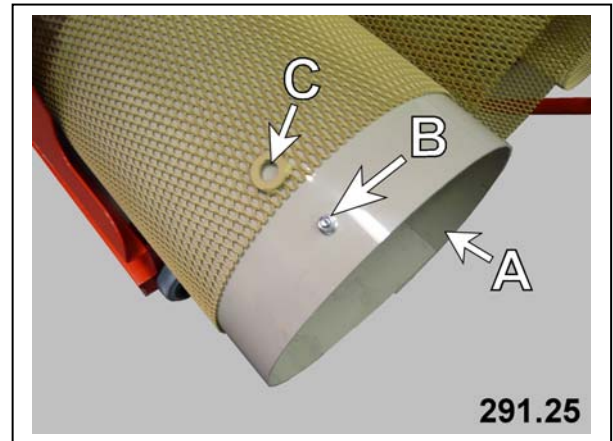

6.7. Power drive

All information required for handling, operating or adjusting the Honda engine can be obtained from the enclosed manufacturer's operating instructions.

The following documents from Honda are contained in the delivery:

1. Operating instructions
DEUTSCH - ITALIANO - NEDERLANDS
2. Operating instructions
ENGLISH - FRANÇAIS - ESPAÑOL
3. Warranty information leaflet
4. Manufacturer's declaration
5. Certificate of emissions
values for the US

7.0. Operation

7.1. General Information

CAUTION!

The self-propelled machine is **NOT** approved for travel on public roads.

The engine exhaust gas contains poisonous carbon monoxide. Do not let the machine run in an enclosed area.

Petrol is extremely flammable and explosive. Switch off the engine and allow it to cool down before refuelling.

You may burn yourself on the hot exhaust pipe. You should avoid touching the exhaust pipe if the engine is in operation.

7.2. Hot surfaces

The following components may become hot during operation:

- Exhaust system (A)
- Engine case (B)
- Oil tank (C)
- Oil cooler (D)

Maintain a safe distance from hot surfaces.

Wear suitable protective gloves.

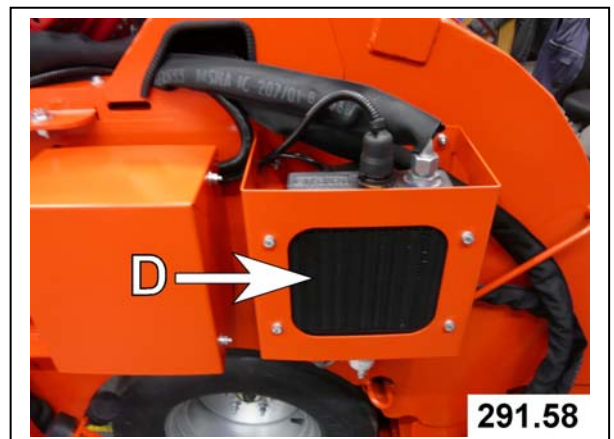
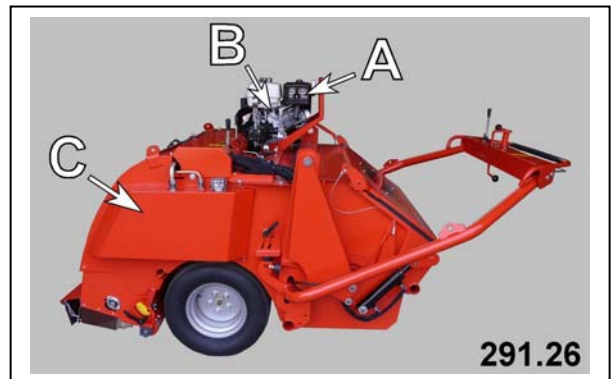

7.0. Operation

7.3. Working with the Core Recycler



CAUTION:

- Never park the machine on a slope.
- The machine must be loaded on a trailer for transportation on public roads.
- When allowing someone else to work with the self-propelled Core Recycler, instruct them on how to use it, and ask them to read the operating instructions.
- Never make the self-propelled Core Recycler available to someone who does not understand these operating instructions and the adhesive safety signs.
- If the self-propelled Core Recycler is operated by someone who is not familiar with it, this can lead to accidents.
- We do not recommend that you operate this self-propelled Core Recycler on slopes.
- On a slope, the gradient, soil conditions, operating mode, grass condition, etc. may cause the self-propelled Core Recycler to slip or tip over, and therefore cause physical injuries.
- If using the self-propelled Core Recycler on a slope, remember that there is no such thing as a **"safe"** slope. Never use the machine on a slope of more than **"10°"**.

7.0. Operation

7.4. Correct sequence for engaging

NOTE:

The control lever (**S6**) for the direction of travel and speed must be in the **0 position**.

Excerpt from the engine manufacturer's operating instructions:

Open the fuel valve.

Set the choke lever to closed

Adjust the throttle to a third of the way

Set the motor switch to ON

Turn the ignition key to START and hold it in this position until the engine starts.

When the engine starts, release the ignition key so that it returns to ON.

Gradually set the choke lever back to open.

Set the throttle to FULL SPEED to reach maximum power.

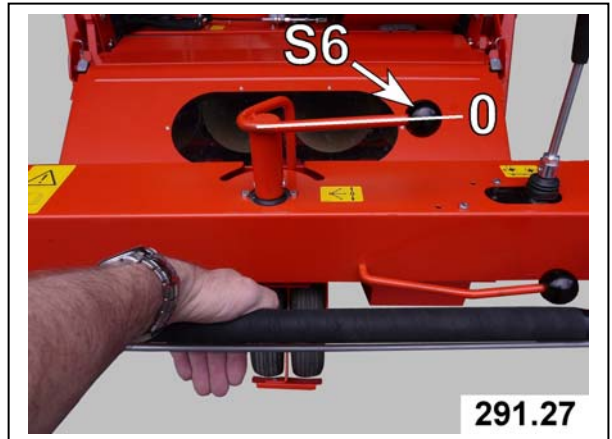

7.5. Driving characteristics

The driving speed is 0 to 6 km/h.

Pay CAUTION to possible dangers which could cause the Core Recycler to tip over.

Never use the machine on a slope of more than "10°".

Always drive the Core Recycler transversely to the contour lines. Never drive along a hillside – **DANGER OF TOPPLING!**

7.0. Operation

7.6. Switching off the machine safely



CAUTION:

- The machine may tip over when switched off. People may be crushed and killed.
- Only switch off the machine on stable and even ground.
- Before adjustment, repair, maintenance and cleaning work, ensure that the machine is positioned securely. If in doubt, support the machine.
- When working with the container raised, the safety latch (see chapter 6.4.) must be activated.
- To park the Core Recycler, pivot the brake lever (A) 180° to the left into position P and the hand brake is applied.
- To release the hand brake, pivot the brake lever (A) 180° to the right.
- **CAUTION !**
Park the Core Recycler on even, firm ground and make sure that the hand brake has been applied correctly.

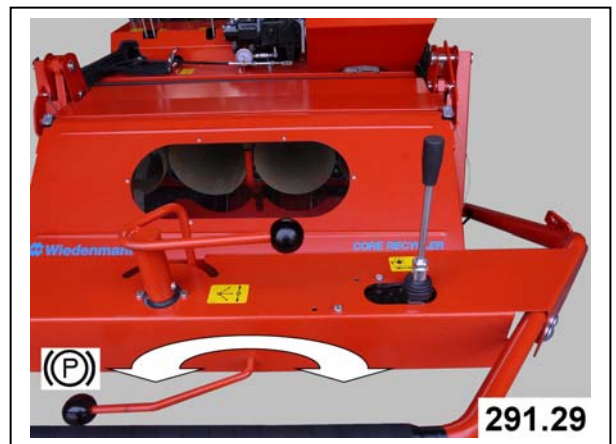

IMPORTANT:

Never drive when the hand brake is applied, otherwise the braking power will decrease rapidly, or the braking system could even be damaged.

7.0. Operation

7.7. Emptying the Dirt Container

1. Switch off the cylinder broom drive with control lever **S1**.
2. Switch off the drum screen drive with control lever **S2**
3. Drive to just before the filling device.
4. Pivot the steering bar to the other side.
5. Lower the sweeping head to the ground.

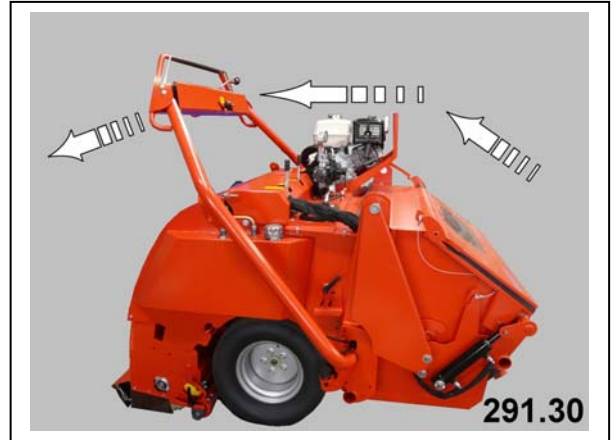

6. The ball valve **S4** is in position **"A"**
7. Push the control lever (**S3**) to the right to raise the container.



CAUTION:

High dumping may NOT be used when the Core Recycler is in an inclined position.
- DANGER OF TOPPLING!



8. Turn the ball valve (**S4**) to position **"B"**
9. Carefully and with container raised, drive towards desired filling device.
10. Push the control lever (**S3**) to the right to empty the container.
11. Drive away from filling device when emptying is completed.



7.0. Operation

7.7. Emptying the Dirt Container

12. Swing the container back:
To do this, push the
control lever **S3** to the
left.



13. Turn the ball valve to
position **"A"**

14. Turn the ball valve to
position **"A"**

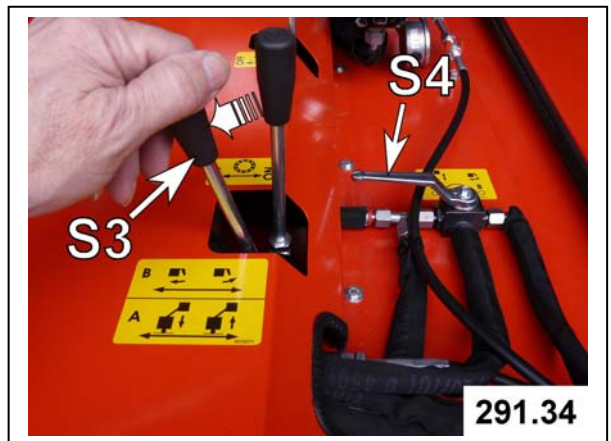

15. Pivot the steering bar to
the other side (working
position **P1**).

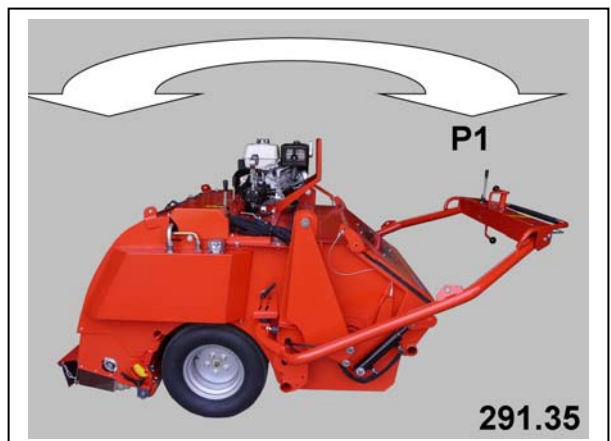

7.0. Operation

7.8. Malfunctions and troubleshooting

Description	Cause	Remedy
The engine does not run when the steering bar is in the working position	No fuel (petrol) in the tank.	Check and, if necessary, top up the fuel.
	The fuel valve may be closed.	Check and, if necessary, open the valve.
	Intake air via the air filter too low.	Check and, if necessary, replace the air filter (see engine manufacturer's operating instructions)
	The control lever S6 is not in the 0 position	Set the control lever S6 to the 0 position
	The dirt container is not completely closed or the button is not pressed.	Check and, if necessary, close the container.
	The electric cable, switch or button is faulty.	Check, and contact a specialist workshop.
	Too little engine oil in the combustion engine	Check the fill level and, if necessary, top up the motor oil (see engine manufacturer's operating instructions)
The engine does not run when the steering bar has been pivoted to the sweeping head side for emptying and the dirt container is still closed.	No fuel (petrol) in the tank	Check and, if necessary, top up the fuel.
	The fuel valve may be closed.	Check and, if necessary, open the valve.
	Intake air via the air filter too low.	Check and, if necessary, replace the air filter (see engine manufacturer's operating instructions)
	The control lever S6 is not in the 0 position	Set the control lever S6 to the 0 position
	The control lever S7 for raising and lowering the sweeping head is not in the floating position	Set the control lever S7 to the floating position
	The electric cable, switch or button is faulty.	Check, and contact a specialist workshop.
	Too little engine oil in the combustion engine	Check the fill level and, if necessary, top up the motor oil (see engine manufacturer's operating instructions)

7.0. Operation

7.8. Malfunctions and troubleshooting

Description	Cause	Remedy
The engine does not run when the steering bar has been pivoted to empty the container and the container is open.	No fuel (petrol) in the tank	Check and, if necessary, top up the fuel.
	The fuel valve may be closed.	Check and, if necessary, open the valve.
	Intake air via the air filter too low.	Check and, if necessary, replace the air filter (see engine manufacturer's operating instructions)
	The control lever S6 is not in the 0 position	Set the control lever S6 to the 0 position
	The control lever S7 for raising and lowering the sweeping head is not in the floating position	Set the control lever S7 to the floating position
	The control lever S2 for the drum screen is switched on "ON"	Switch the drive off "OFF"
	The electric cable, switch or button is faulty.	Check, and contact a specialist workshop.
	Too little engine oil in the combustion engine.	Check the fill level using the dipstick and, if necessary, top up the motor oil (see engine manufacturer's operating instructions)
The engine stops when the control lever S6 is actuated by the drive unit.	The safety bar S5 is not held	The safety bar S5 must be held (See chapter 6.2.)
	Hand brake applied	Release the hand brake.
	The electric cable, switch or button is faulty.	Check, and contact a specialist workshop.
The engine stops when the control lever S3 is actuated	The steering bar is in the working position	Pivot the steering bar to the sweeping head side
The wheels do not turn, or the drive unit does not provide sufficient power when the control lever S6 is actuated by the drive unit.	The bypass is switched off.	Move the bypass lever, (see chapter 3.3.)
	Hand brake (S8) applied	Release the hand brake (S8)
	The band brake is jammed	Release the band brake and readjust (see chapter 8.9.)

7.0. Operation

7.8. Malfunctions and troubleshooting

Description	Cause	Remedy
The wheels do not turn, or the drive unit does not provide sufficient power when the control lever S6 is actuated by the drive unit.	The oil fill level in the hydraulic reservoir is too low.	Fill up the oil until the fill level can be seen in the filling screen.
	The hydraulic oil is too hot (over 75 °C).	Check that the fan wheel on the oil cooler is working correctly and, if necessary, replace the locking device (battery box) or check the earth connection.
	The oil cooler motor or the electric wiring is faulty.	Contact a specialist workshop.
During separation of the material, cores are only collected from the cylinder broom to a limited extent.	The speed of the cylinder broom is too slow.	The hydraulic oil is not at the operating temperature. As a result, the hydraulic motor of the cylinder broom turns too slowly.
		Check the nominal speed of the motor and, if necessary, set to a maximum of 3300 rpm (see the motor manufacturer's operating instructions)
		Clean the rear wall of the sweeping head using a cleaning rod in the area of the brush holder due to heavy soiling (see chapter 8.5.).
	The cylinder broom is set too deep.	Adjust the cylinder broom using the feeler roller (see chapter 6.3.)
	The cylinder broom is set too high; the cores are not gathered by the brush.	Adjust the cylinder broom using the feeler roller (see chapter 6.3.)
	Incorrect area of application, the grass may be too high.	Pay CAUTION to the specified use, (see preface on page 4)
Due to worn bristles on the cylinder broom, there is too large a distance to the front wall (more than 10 mm)	Adjust the gap between the cylinder broom and the front wall to 3 – 4 mm, and, if necessary, replace the cylinder broom (see chapter 8.19.)	

7.0. Operation

7.8. Malfunctions and troubleshooting

Description	Cause	Remedy
The machine cannot be towed, because the drive wheels lock.	The bypass is not switched off.	Move the bypass lever, (see chapter 3.3.)
The machine continues rolling despite the hand brake being applied.	The clearance between the band brake and the disc is too wide.	Check the permissible clearance and, if necessary, adjust it using the brake cable; otherwise, replace the band brake (see chapter 8.9.).
The drum screens do not turn when the drive is switched on	The drum screens are not inserted accurately into the guide/synchronisation.	Raise the container and check that the drum screens are correctly installed (see chapter 8.6.)
During complete material collection, the intake material is only collected from the cylinder broom to a limited extent.	The intake material and cores are still too damp.	Leave the intake material to dry more.
		Otherwise, convert the machine to material separation, and, if necessary, increase the tilt angle of the screens, resulting in lower screening (see chapter 6.6.)
	The speed of the cylinder broom is too slow.	The hydraulic oil is not at the operating temperature. As a result, the hydraulic motor of the cylinder broom turns too slowly.
		Check the nominal speed of the motor and, if necessary, set to a maximum of 3300 rpm (see the motor manufacturer's operating instructions)
		Clean the rear wall of the sweeping head using a cleaning rod in the area of the brush holders due to heavy soiling (see chapter 8.5.).

7.0. Operation

7.8. Malfunctions and troubleshooting

Description	Cause	Remedy
During complete material collection, the intake material is only collected from the cylinder broom to a limited extent.	The cylinder broom is set too deep.	Adjust the cylinder broom using the feeler roller (see chapter 6.3.)
	The cylinder broom is set too high; the intake material is not gathered by the brush.	Adjust the cylinder broom using the feeler roller (see chapter 6.3.)
	Incorrect area of application, the grass may be too high.	Pay CAUTION to the specified use, (see preface on page 4)
	Due to worn bristles on the cylinder broom, there is too large a distance to the front wall (more than 10 mm)	Adjust the gap between the cylinder broom and the front wall to 3 – 4 mm, and, if necessary, replace the cylinder broom (see chapter 8.19.)
During separation of the material, the desired sand division is not carried out during the screening.	The intake material and cores are still too damp, resulting in uneven sand deposits.	Leave the material to dry more and the result will improve.
	Speed is too high	Lower the speed, which will lead to an improved result.
During separation of the material, the proportion of sand in the container is too high.	The speed is too high for damp intake material and cores.	Lower the speed in damp conditions, due to lower pourability of the separating material.
	The openings of the drum screens are partially blocked.	Clean and adjust the cleaning brushes and scrapers (see chapters 8.7. and 8.8.)
The drum screen cleaning brushes are clogged.	The scraper for these brushes is not installed correctly.	Clean and adjust the cleaning brushes and scrapers (see chapters 8.7. and 8.8.)
Increased wear on the cylinder broom	The cylinder broom is severely clogged	Clean with a cleaning rod, (see chapter 8.2.).

8.0. Maintenance

8.1. General Information



ATTENTION DANGER:

Only qualified personnel are permitted to perform maintenance, repair and disassembly tasks.

For repair, maintenance and cleaning work, as well as for rectifying malfunctions, the machine must always be parked on an even, paved surface and secured against rolling away.

For all work with the container raised, the safety latch (see chapter 8.3.) must be activated. There is a risk of injury due to the container dropping unexpectedly.

Before starting any maintenance or repair work, the engine must be switched off. Remove the ignition key to prevent accidental start-up. In this way, possible risks can be eliminated:

- Carbon monoxide poisoning due to engine exhaust gases
- Burning due to contact with hot parts
- Injuries due to contact with moving parts.

Use your personal protective equipment (PPE) for work, such as:

- Work gloves;
- Safety shoes;
- Breathing protection;
- Ear protectors;
- Face and eye protection, etc.

Use **only original parts**. Third-party parts often do not match the required quality and thus endanger your safety. Moreover, the sustained warranty and recognition of justified warranty claims can only be guaranteed, if you exclusively use **original parts from Wiedenmann**.

We would like to draw your CAUTION, in particular, to the fact that original parts which are not supplied by Wiedenmann have neither been tested nor approved by Wiedenmann. The installation and/or employment of such products can, in some circumstances therefore, have negative structural effects on **your self-propelled machine** and negatively affect active and/or passive safety.

Damages arising from the use of non-original parts are excluded from the scope of the manufacturer's liability.

After maintenance, remove all parts that do not belong to the self-propelled machine. Then reinstall all safety covers/guards.

All information required for performing maintenance on the Honda engine can be obtained from the enclosed manufacturer's operating instructions.

8.0. Maintenance

8.2. Maintenance and inspection list

Maintenance Interval	Area	Maintenance Task
Daily	Whole machine	Clean the machine (see chapter 8.5.)
	Rear of the sweeping head	Clean with a cleaning rod (see chapter 8.5.)
	Hydraulic lines	Check for leaks
As required	Rear of the sweeping head	Clean several times with a cleaning rod in wet conditions
	Wheels	Check the tyre pressure and, if necessary, correct (see chapter 8.18.)
Weekly	Drum screen gear ring and gear wheels	Check the shape of the gear wheels (see chapter 8.6.)
Annually	Machine	Conserve
300 hours or 36 months	Hydraulic oil in the oil tank	Drain the hydraulic oil and refill the tank (see chapter 8.16.)
	HONDA - engine	All information required for performing maintenance on the Honda engine can be obtained from the enclosed manufacturer's operating instructions.

8.0. Maintenance

8.3. Safety locking mechanism with raised container



CAUTION:

Before all work on the raised container, the safety lock mechanism must always be engaged to prevent the container from dropping unexpectedly.
- RISK OF INJURY !

- Raise container fully during high dumping.
- Pull the ball valve lever backwards and rotate it outwards by 90° (see Figure 398.29).
- Pull the ball valve lever backwards and rotate it backwards by 90° to release the container.

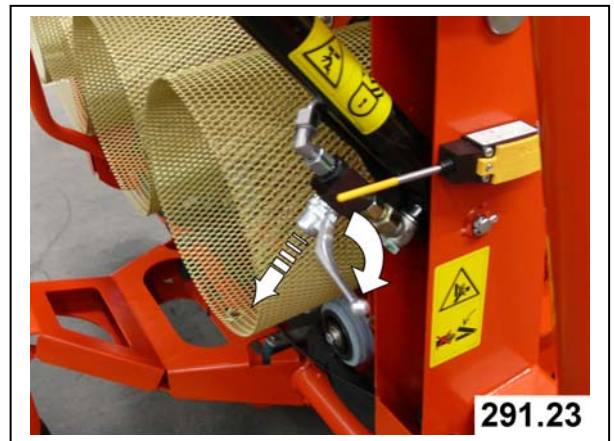

8.4. Removing the cleaning flap

Undo the fixing screw (A).

The cleaning flap (B) can easily be lifted off the sweeping head.

Unhook the rubber hood catches (C).

The fixing screw (A) stays on the flap (B).

Hook the flap at the top and secure with the fixing screw (A).

Hook the rubber hood catches (C).

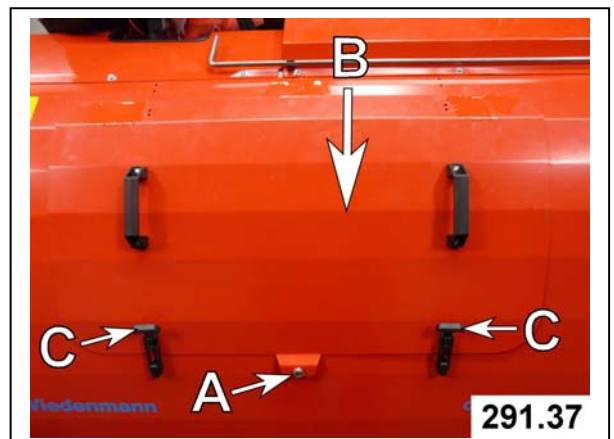

8.0. Maintenance

8.5. Cleaning the Core Recyclers



ATTENTION:

Cleaning must only be carried out using hand brushes or water
- never with bare hands.
- **RISK OF INJURY!**

Clean the machine daily when work is completed to ensure smooth operation next time.

Main cleaning points are:

- Cylinder broom
- Sweeping head channel
- Drum screen in the container
- Brushes for the drum screen
- after usage on wet grounds, we recommend that you check the intake channel and if necessary clean.

Cleaning with a cleaning rod

Areas at the rear of the sweeping head which would otherwise be difficult to reach can be cleaned with the cleaning rod (A).

Thread the cleaning rod (A) into the holes on both sides.

By pulling the cleaning rod (A) back and forth, the material residue is removed.

The sweeping head can be raised into the loading position for cleaning with a steam jet unit (see description in chapter 3.2.3.).

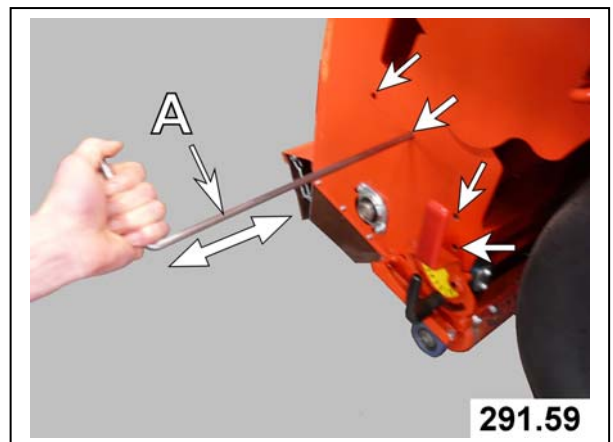

8.0. Maintenance

8.6. Cleaning the drum screen

Use your personal protective equipment (PPE) for work.

Pivot the steering bar to the sweeping head side.

Apply the hand brake.

Raise the container and activate the safety latch (see chapter 8.3.).

Switch off the engine and remove the ignition key.

Swing the safety angle (A) outwards.

Undo the tension locks (B).

Raise the drum brush (C) slightly and remove it.

Use your personal protective equipment (PPE) for work.

Pivot the steering bar to the sweeping head side.

Apply the hand brake.

Raise the container and activate the safety latch (see chapter 8.3.).

Switch off the engine and remove the ignition key.

Swing the safety angle (A) outwards.

Undo the tension locks (B).

Raise the drum brush (C) slightly and remove it.

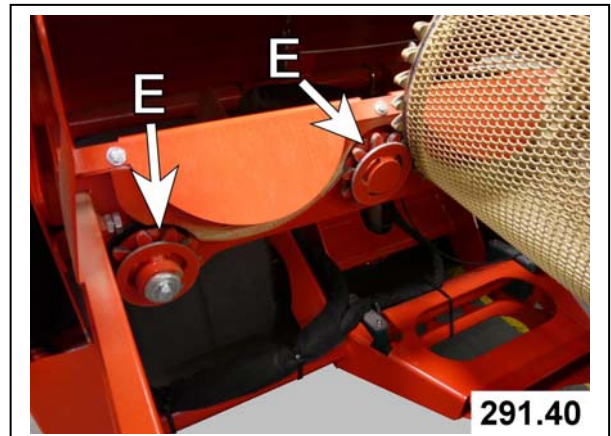
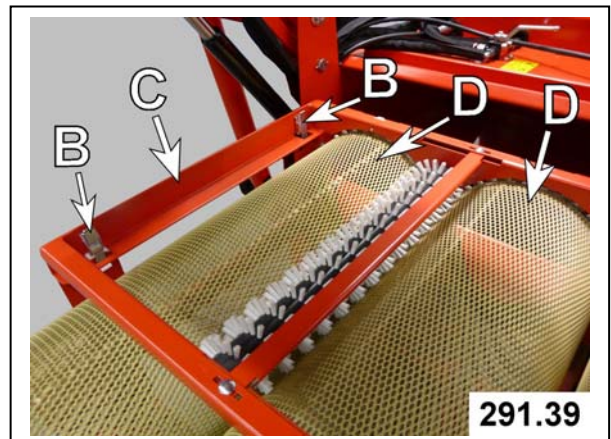
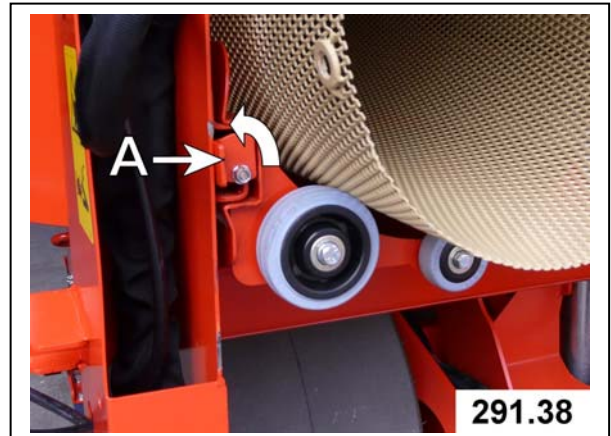

8.0. Maintenance

8.7. Adjusting the brush for the drum screen

Release the hexagon nuts **(A)** on both sides.

The entire length of the brush **(B)** should be pressed lightly against the drum screens.

Tighten the hexagon nuts **(A)** to secure the setting.

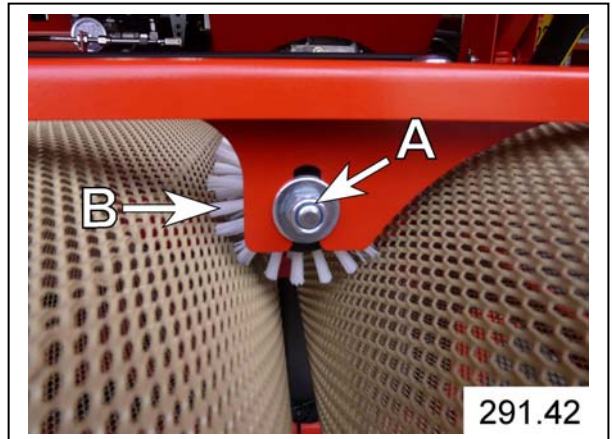

8.8. Adjusting the scraper for the drum screen brush

Undo the fixing screws **(A)**.

Slide the scraper **(B)** towards the brush **(C)** until it only touches the ends of the bristles lightly.

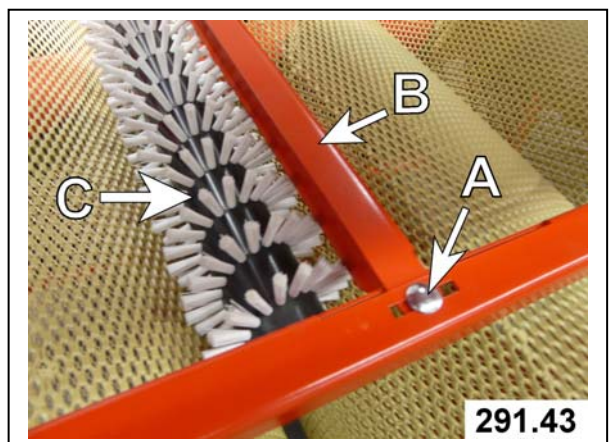

8.0. Maintenance

8.9. Adjusting or resetting the hand brake

Steering bar in the working position.

Switch off the machine safely and secure it against rolling away.

Disassemble the drive wheel

The brake pad (A) should be able to move freely when the hand brake is released.

If the brake pad is too loose or the braking action is too low when the hand brake is applied:

The hand brake can be reset using the pull rope.

The first adjustment screw is in the steering bar (see arrow in Fig. 291.45).

The second adjustment screw is under the drum screens on the frame (see arrow in Fig. 291.46).

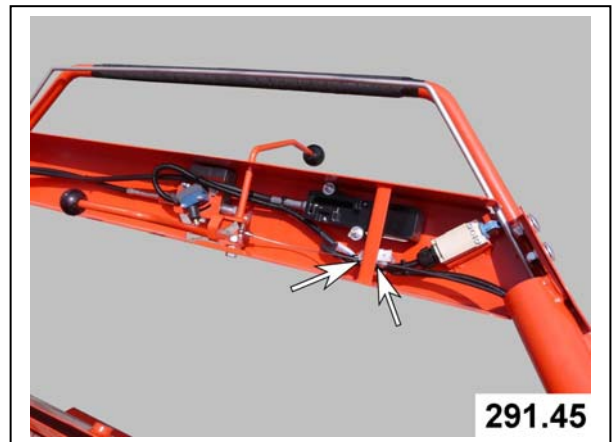
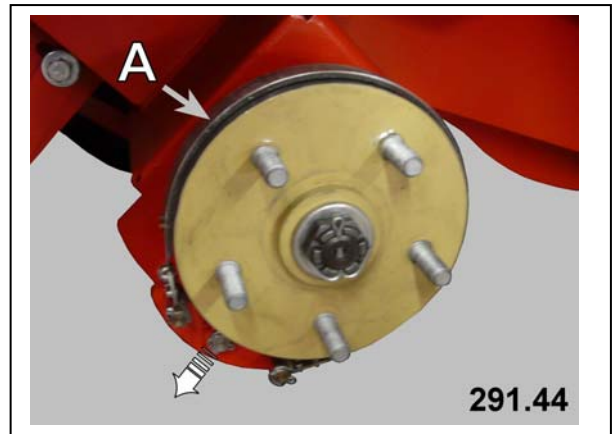

8.0. Maintenance

8.10. Checking and charging the battery



CAUTION DANGER!

The battery may explode due to improper handling of the battery, for example, accidentally connecting the battery poles with a metal object. This can cause serious injuries and burns. Oxyhydrogen is produced by the battery, for example, due to charging the battery for a long time. A spark can ignite the oxyhydrogen. People may be injured by the explosion and burnt by any battery acid which sprays out.

- Use a suitable voltmeter to check the battery condition.
- Keep the battery away from fire, sparks or naked flames.
- To charge the battery outside the self-propelled machine, proceed as described in chapter 8.12.

8.11. Electrical system

Remove dust, grass and leaves from the battery, wiring, exhaust pipe and engine to prevent the risk of fire.

If the machine is not used for a long time, disconnect the battery cable. This prevents short circuits and the risk of fire.

8.0. Maintenance

8.12. Removing and fitting the battery

Undo the hexagon nuts (A).
Remove the protective cover (B).

To disconnect the battery, always disconnect the earth cable (-) first.

Release the tensioning strap
When installing the battery, secure it with the tensioning strap.

To connect the battery, always connect the positive cable (+) first. Incorrect connection may cause short circuits and sparks.

Secure the line (A)
with **15 A**

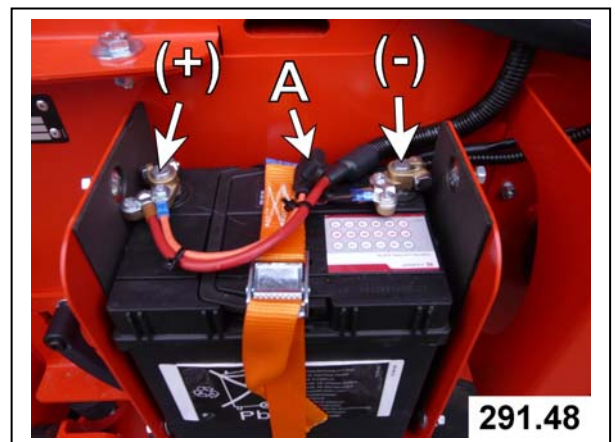
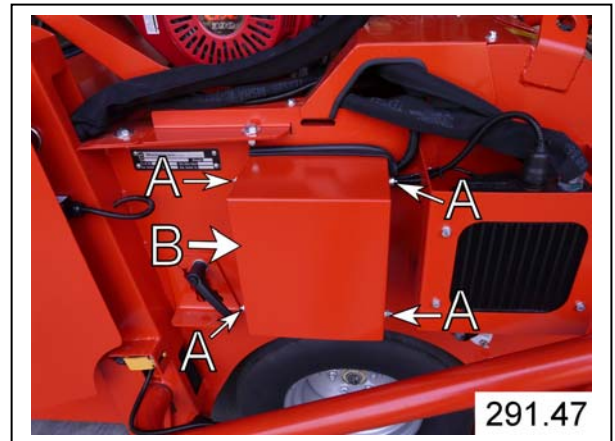

8.13. Lubrication – General Information

- Before carrying out any work, the engine of the machine and the tractor engine must be switched off.
- Lubricate more often, if required, (until all lubrication points are sufficiently lubricated).
- Always keep all exposed machine parts, threaded spindles and guides lightly lubricated.
- Clean grease nipple before lubrication.
- Clean up leaking grease.
- Before starting the machine after a longer standstill, lubricate and maintain the entire machine.

8.0. Maintenance

8.14. Lubrication (weekly)

The points indicated in the figure by the arrows must be lubricated once a week.

The figures only show one of several corresponding assembly groups with lubrication points.

Bearing system of the steering wheels

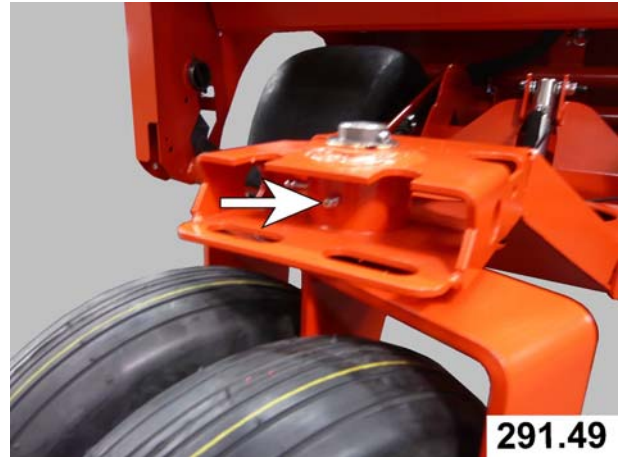

Vertical bearing of the roller

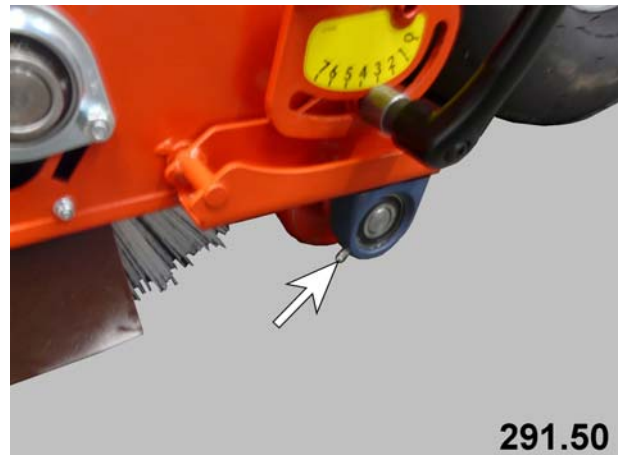

Bearing system of the steering bar



8.0. Maintenance

8.15. Oil change on Honda engine

Pivot the steering bar to the other side.

Raise the container

Engage the safety latch

Switch off engine

Switch off the collecting tray under the engine on the drum screen.

Remove oil drain plug (A).

Remove cap (B) from the oil filler.

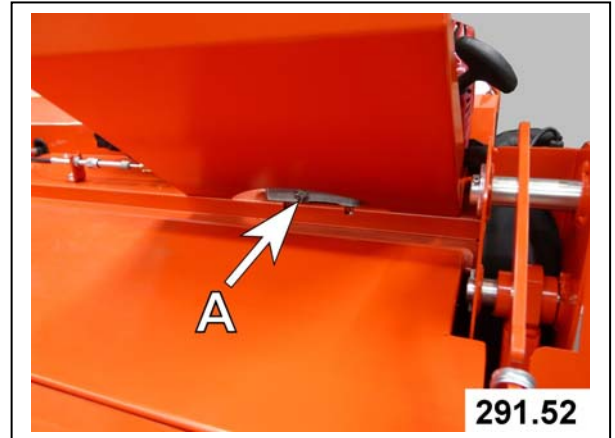

Insert oil drain plug (A) before filling.

Please refer to the enclosed manufacturer's operating instructions for the required oil type and volume.

IMPORTANT:

Strictly observe the regulations and laws concerning the disposal of environmentally hazardous substances. Get detailed information about their disposal.

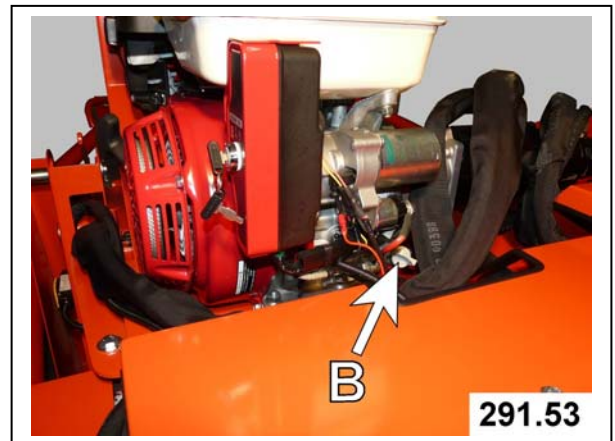

8.16. Replacing the hydraulic oil

Switch off the collecting tray under the oil tank.

Remove oil drain plug (A).

Insert oil drain plug (A) before filling.

Pour in approx. **18** litres of hydraulic oil until the oil level can be seen in the filling screen.

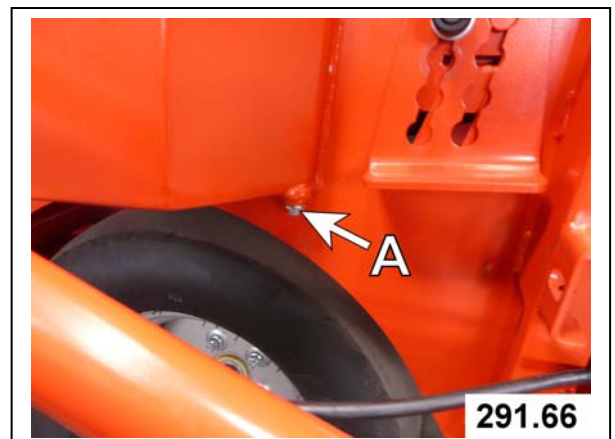

8.0. Maintenance

8.17. Care and maintenance of the hydraulic system

Examine hydraulic hose lines regularly for damage and ageing and replace if necessary. According to the manufacturer's specifications, the replacement period for hydraulic lines is 6 years.



CAUTION !

The hydraulic system is not approved for the use of BIO oils !



CAUTION:

High-pressure fluids leaking under high pressure can penetrate the skin, causing serious injury. For this reason, depressurise the system before disconnecting lines. Before building up pressure in the system again, ensure that all line connections are leak-tight. It is difficult to see hydraulic oil leaking from a small opening. For this reason, use a piece of cardboard when searching for leaks.

Protect the hands and body from high-pressure fluids.

If a fluid has penetrated the skin, this must be removed immediately by a doctor familiar with this type of injury; otherwise serious infections are possible. Doctors who are unfamiliar with this type of injury should obtain the relevant information from a competent medical source.

8.0. Maintenance

8.18. Removing and fitting the cylinder broom

Undo the headless screws (A).

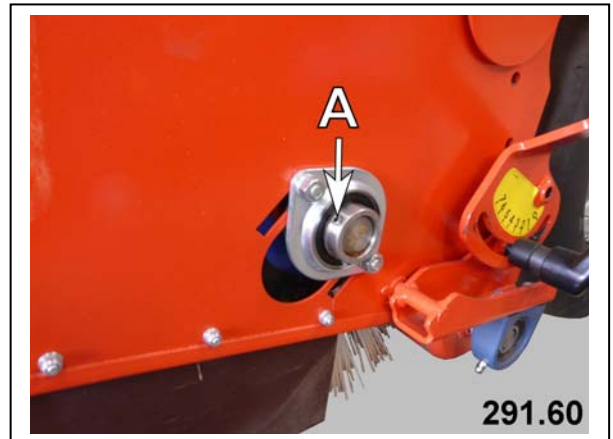

Undo the cylinder head screws (B).

Unlock the sweeping head and raise it to the uppermost position.

Pull the hydraulic motor (C) outwards.

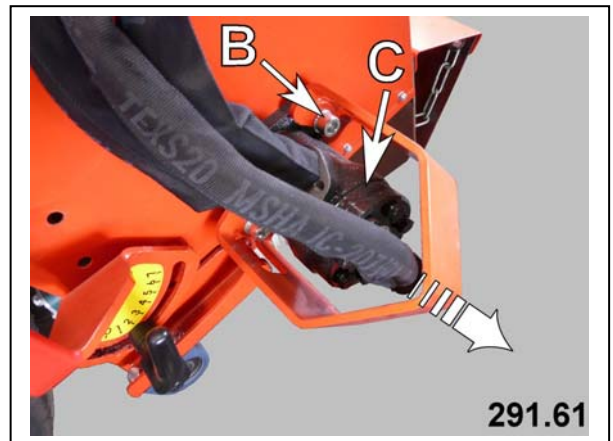

Pull out the entire cylinder broom (D) diagonally downwards.

Replace the cylinder broom (D) of the drive shaft (E).

NOTE:

Before you push the drive shaft into the cylinder broom, take note of the correct installation position (see Fig. 291.63).

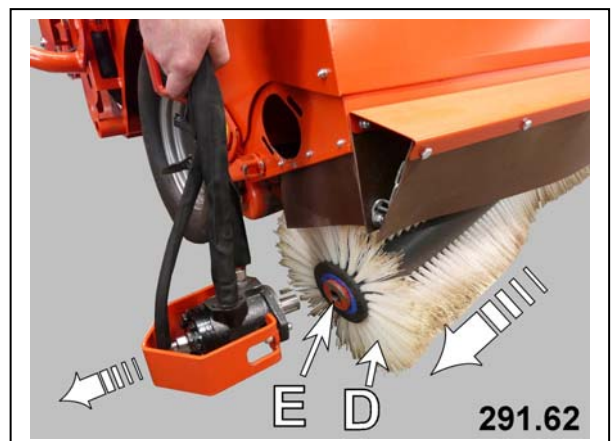

8.0. Maintenance

8.18. Removing and fitting the cylinder broom

Fit the spacer ring (F) with a large diameter on the cylinder broom.

Push the cylinder broom from the engine side into the sweeping head and flange bearing.

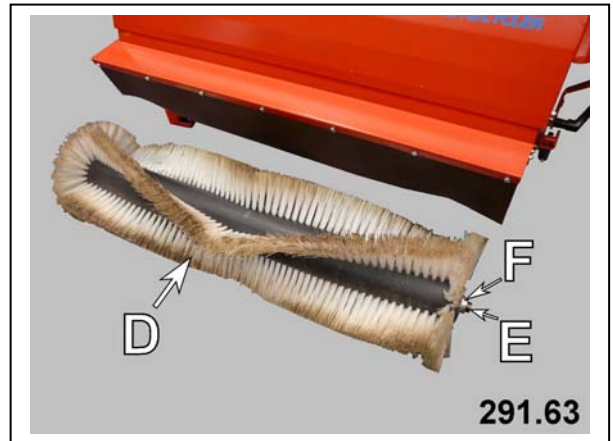

Push the hydraulic motor (C) into the appropriate profile on the shaft with a feather key.

Secure the hydraulic motor (C), including the safety bar (G), with the cylinder head screws (B).

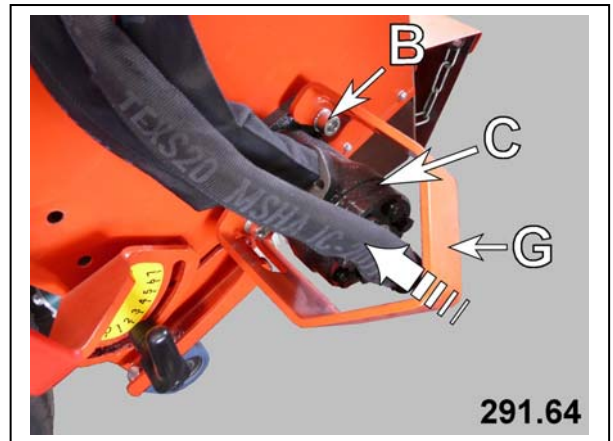

NOTE:

Always fit new cylinder brooms in the uppermost position.

Tighten the headless screws (A).

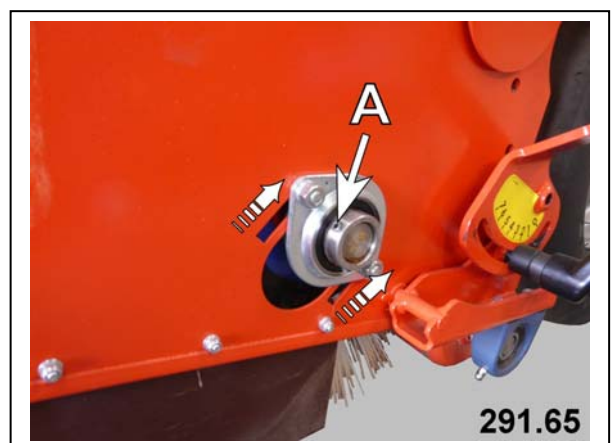

8.0. Maintenance

8.19. Wheels and Tyres

Regularly check the tyre pressure:

Drive wheels **0,8 bar / 12 psi**

Steering wheels **1,4 bar / 20 psi**



CAUTION:

Serious or fatal injuries can be caused by the explosion-type bursting of the tyres and by the rim parts.

Only carry out tyre installation if you have appropriate experience and equipment.

Always adhere to the recommended tyre pressure. Never inflate the tyres over the recommended pressure. Do not heat the wheels or tyres or carry out welding on them. Heating the tyres can lead to explosion-type tyre bursts as the pressure in the tyre thereby becomes very high. Welding can lead to deformations or damage of the wheel.

When inflating the tyres, select a filling connection with a safety clip and an extension hose with sufficient length so that you can stand to one side when inflating the tyres. Never stand in front of or on the tyre. If available, use a safety cage.

Check wheels and tyres daily for low pressure, slits, bulges, damaged rims, missing wheel bolts or -nuts.

8.0. Maintenance

8.20. Disassembly / disposal



CAUTION :

Proceed carefully when disassembling the machine. Please refer to the chapter "Safety measures" and local safety regulations.

The dangers are as follows:

- Residual pressure in lines and components,
- heavy parts that could fall after disassembly,
- sharp edges,
- The parts might topple over and crush someone.

Disassembly for disposal :

1. Place the equipment on firm ground.
2. Drain hydraulic oil.
3. Drain engine oil.
4. **Drain the tank contents.**
5. Disassemble the machine, working from top to bottom.

IMPORTANT :

Specifications and laws concerning the disposal of hazardous substances and pollutants must be observed in all cases. Familiarize yourself completely with the procedure for disposal.

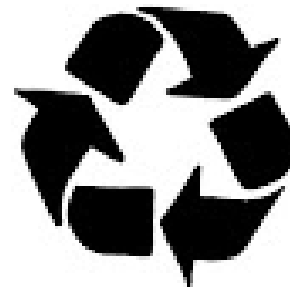

8.0. Maintenance

8.21. Unauthorised modification and spare part manufacturing

Conversion and modifications to the machine are permitted only after prior consultation with the manufacturer!

Original spare parts and accessories authorised by the manufacturer guarantee your safety.

The use of other parts can change the properties of the machine. We accept no liability for consequences which occur for this reason.

9.0. Equipment

9.1. Scope of Delivery

- Hand-guided Core Recycler with:
 - Combustion engine
 - Hydrostatic drive unit
 - Hydraulic high dumping
 - Hydraulic drum screen drive
 - Hydraulic cylinder broom drive
 - Collecting container with a volume of 400 litres
- Engine manufacturer's operating instructions
- Operating instructions, transfer declaration with guarantee card.

9.2. Accessories

Insert

Are already installed in the drum screen when delivered.

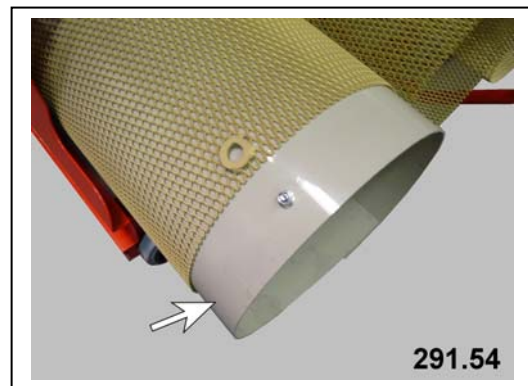

Cleaning rod

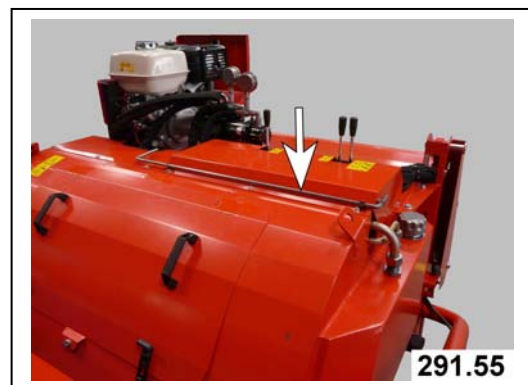

10.0. Technical Specifications

10.1. Technical Data

A	Machine length	2720 mm
B	Machine width	1777 mm
C	Machine height	1504 mm
D	Working width	1200 mm
E	Height to bottom container edge during high dumping	1635 mm
F	Height up to emptying strut	1465 mm
G	Excess length to the lower edge of the container	394 mm
H	Height to the middle of the steering bar (in the working position)	1065 mm
	Power drive	Honda GX 390
	Motor capacity	8,7 KW / 11,8 PS
	Contents of the unleaded petrol fuel tank	6,1 Liter
	Motor oil - filling capacity	1,1 litre
	Nominal engine speed	Max. 3300 1/min
	Please refer to the enclosed manufacturer's operating instructions for all further engine details.	
	Cylinder broom working speed	850 1/min
	Continuously variable drive unit	0 – 6 km/h
	Operating speed	0 bis 6 km/h
	Tank capacity of hydraulic oil	18 litre
	Hydraulic oil grade	Trectrol super 2000 CD-HC
	Tyre equipment at back	13x5.00-6 / 4PR
	Diameter of tires	330 mm
	Tyre pressure	1,4 bar / 20 psi
K	Rear track	130 mm
	Tyre equipment at front	24x13.00-12 / 4PR
	Diameter of tires	602 mm
	Tyre pressure	0,8 bar / 12 psi
L	Front track	930 mm
	Capacity of the collecting container	400 litre
	Weights:	
	Total weight without additional load	650 kg
	Max. permissible payload	180 kg

10.0. Technical Specifications

10.1. Technical Data

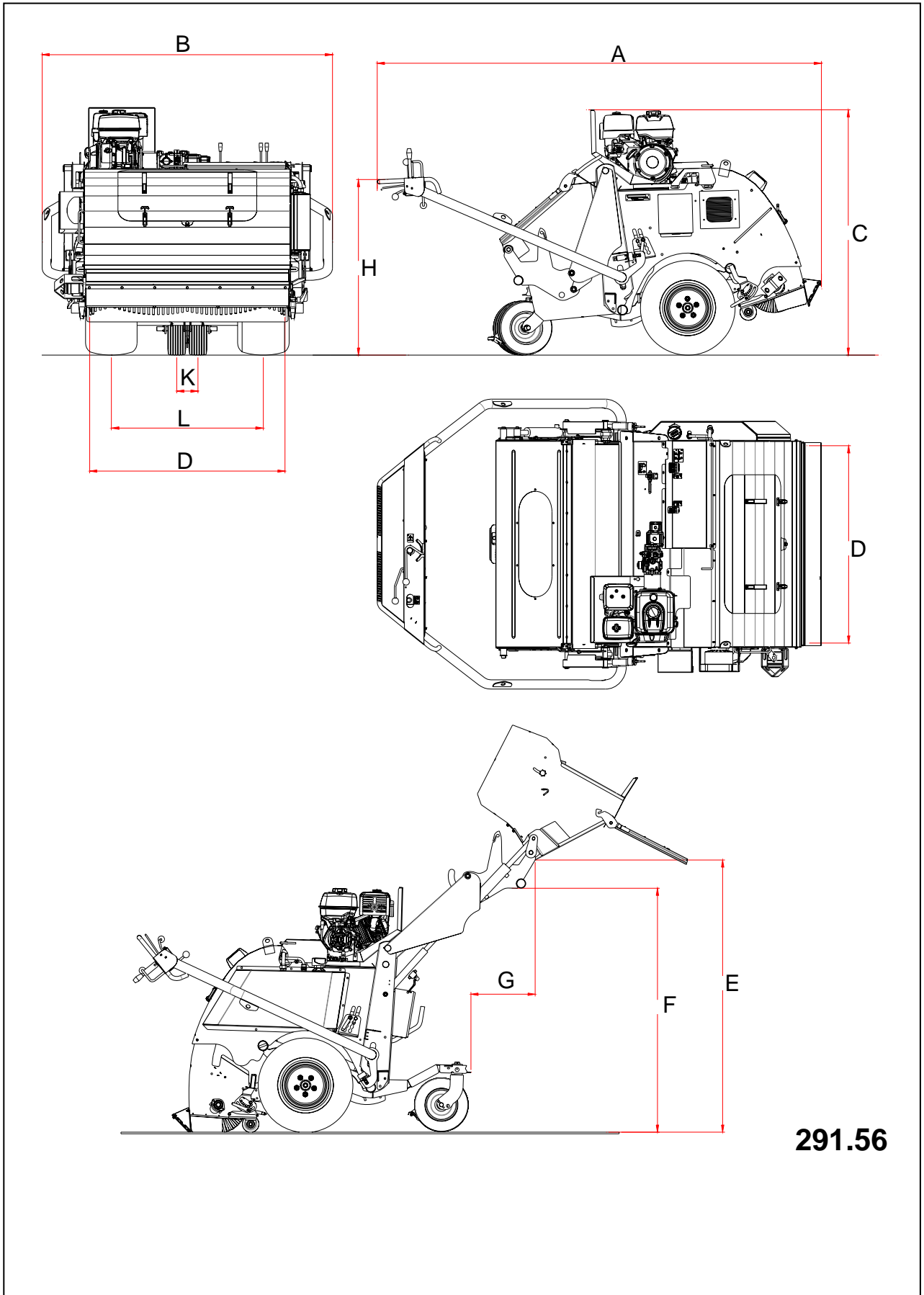

10.0. Technical Specifications

10.2. Metric bolt and cap screw torque values

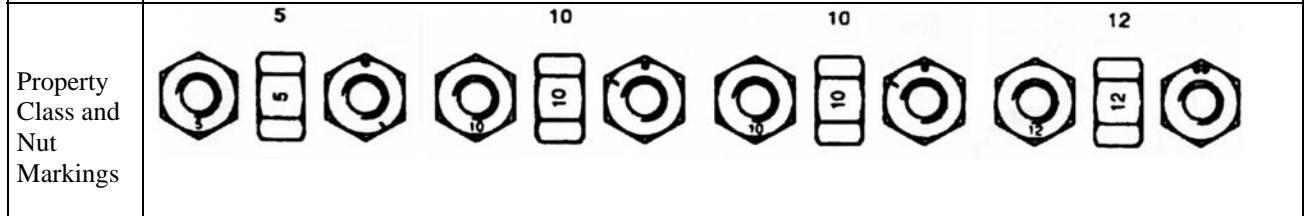
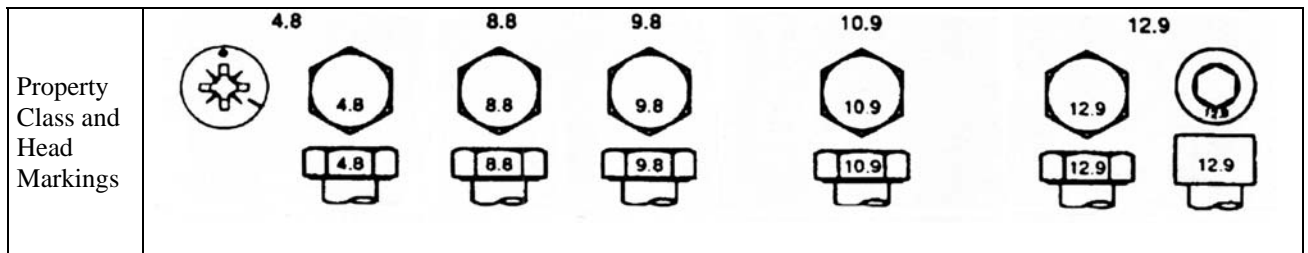

Size	class 4.8				class 8.8 or 9.8				class 10.9				class 12.9			
	Lubricated *		Dry **		Lubricated *		Dry **		Lubricated *		Dry **		Lubricated *		Dry **	
	N-m	lb-ft	N-m	lb-ft	N-m	lb-ft	N-m	lb-ft	N-m	lb-ft	N-m	lb-ft	N-m	lb-ft	N-m	lb-ft
M6	4,8	3,5	6	4,5	9	6,5	11	8,5	13	9,5	17	12	15	11,5	19	14,5
M8	12	8,5	15	11	22	16	28	20	32	24	40	30	37	28	47	35
M10	23	17	29	21	43	32	55	40	63	47	80	60	75	55	95	70

M12	40	29	50	37	75	55	95	70	110	80	140	105	130	95	165	120
M14	63	47	80	60	120	88	150	110	175	130	225	165	205	150	260	190
M16	100	73	125	92	190	140	240	175	275	200	350	255	320	240	400	300

M18	135	100	175	125	260	195	330	250	375	275	475	350	440	325	560	410
M20	190	140	240	180	375	275	475	350	530	400	675	500	625	460	800	580
M22	260	190	330	250	510	375	650	475	725	540	925	675	850	625	1075	800

M24	330	250	425	310	650	475	825	600	925	675	1150	850	1075	800	1350	1000
M27	490	360	625	450	950	700	1200	875	1350	1000	1700	1250	1600	1150	2000	1500
M30	675	490	850	625	1300	950	1650	1200	1850	1350	2300	1700	2150	1600	2700	2000

M33	900	675	1150	850	1750	1300	2200	1650	2500	1850	3150	2350	2900	2150	3700	2750
M36	1150	850	1450	1075	2250	1650	2850	2100	3200	2350	4050	3000	3750	2750	4750	3500

DO NOT use these values if a different torque value or tightening procedure is given for a specific application. Torque values listed are for general use only. Check tightness of fasteners periodically.

Shear bolts are designet to fail under predetermined loads. Always replace shear bolt with identical property class

Fasteners should be replaced with the same or higher property class. If higher property class fasteners used, these should only be tightened to the strength of the original.

** "Lubricated" means coated with a lubricant such as engine oil, or fasteners with phossphate and oil coatings.

Make sure fasteners threads are clean and that you properly start thread engagement. This will prevent them from failing when tightening.

Tighten plastic insert or crimped steel-type lock nuts to approximately 50 percent of the dry torque shown in the chart, applied to the nut, not to the bolt head. Tighten toothed or serrated-type lock nuts to the full torque value.

** "Dry" means plain or zinc platend without any lubrication.

10.0. Technical Specifications

10.3. Chassis Number

Enter the respective product identification no. in the space provided below. Always quote this number when ordering spare parts or in case of warranty claims.

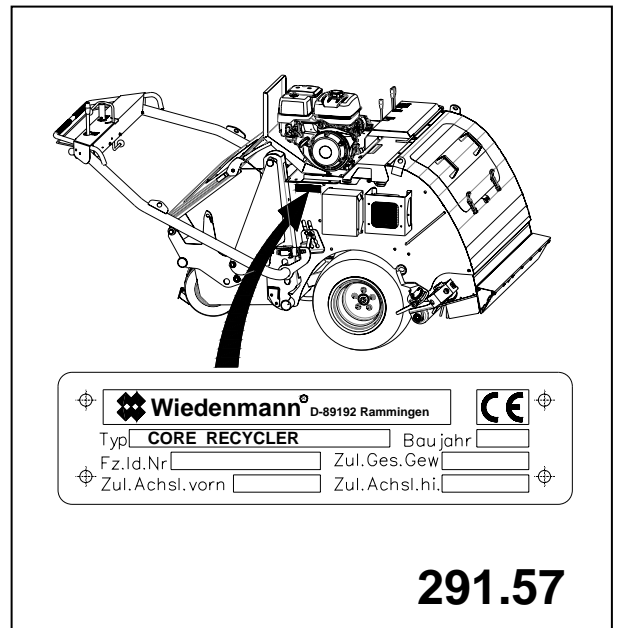

Veh. Id. no.....